

| REVISIONS | | |
|-----------|------|-----|
| DATE | NAME | NO. |
| | | |
| | | |
| | | |
| | | |
| | | |

NOTE:
THIS SHEET HAS BEEN DRAWN USING COMPUTER AIDED DRAFTING/DESIGN (CADD) AND COORDINATE GEOMETRY (COGO).

ATLANTIC AVENUE
(100' R.O.W.)

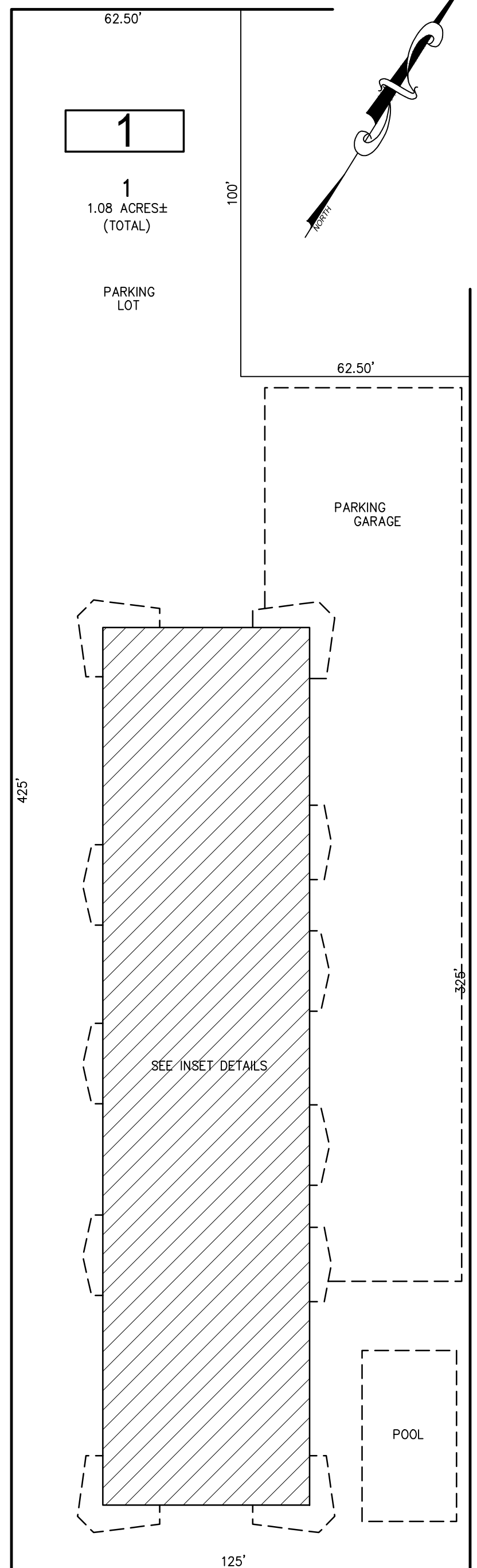

PLAN
SCALE: 1"=30'

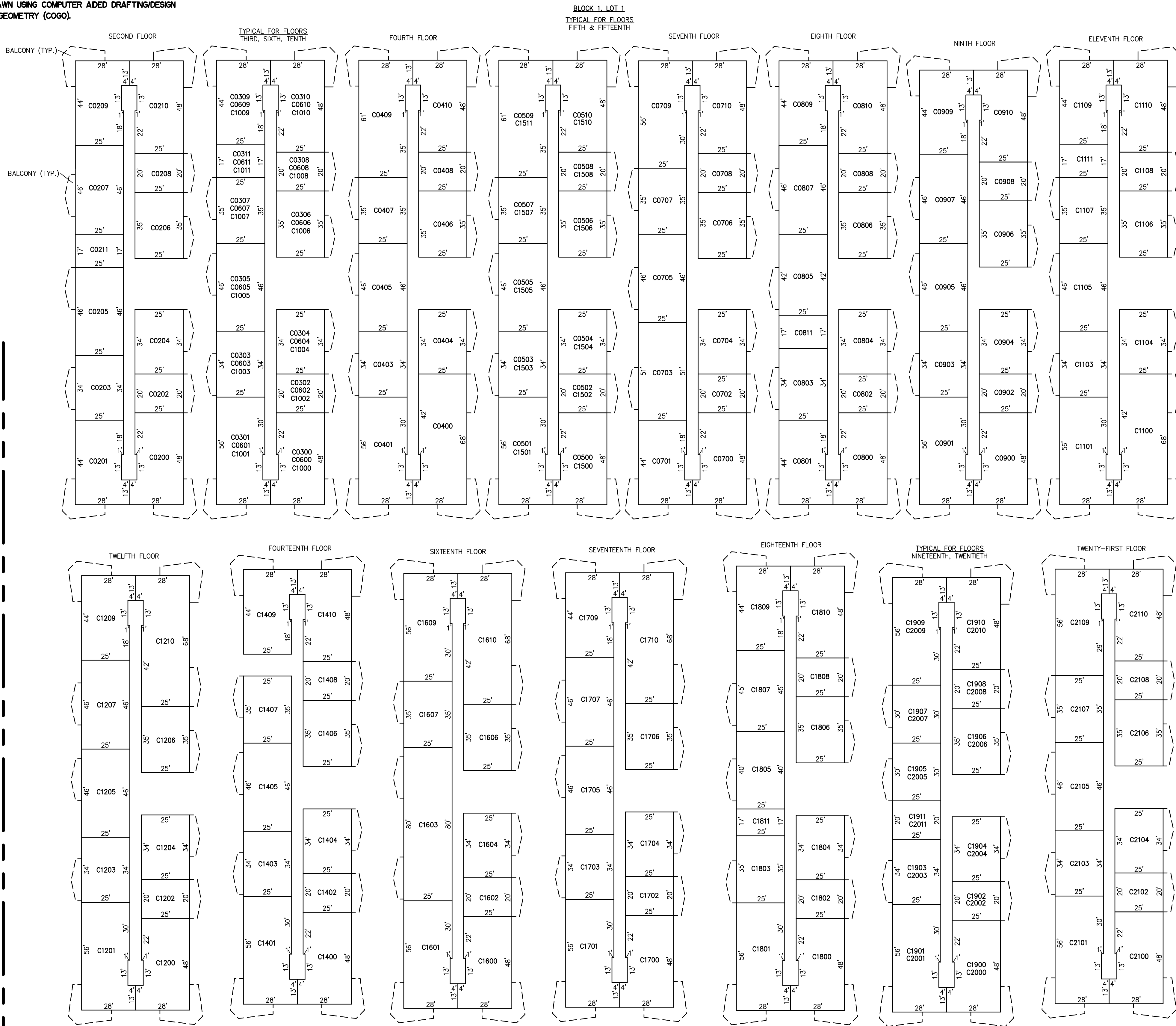

DETAILS
SCALE: 1"=30'

**BLOCK 1, LOT 1
VASSAR SQUARE CONDOMINIUM
4800 BOARDWALK**

BLOCK 1, LOT 1
SEE SHEET 1

| CONDO QUALIFIER | SQUARE FOOTAGE | CONDO QUALIFIER | SQUARE FOOTAGE | CONDO QUALIFIER | SQUARE FOOTAGE |
|-----------------|----------------|-----------------|----------------|-----------------|----------------|
| C0200 | 1120 SF. | C1000 | 1120 SF. | C1900 | 1120 SF. |
| C0201 | 1110 SF. | C1001 | 1398 SF. | C1901 | 1398 SF. |
| C0202 | 492 SF. | C1002 | 492 SF. | C1902 | 492 SF. |
| C0203 | 840 SF. | C1003 | 840 SF. | C1903 | 840 SF. |
| C0204 | 840 SF. | C1004 | 840 SF. | C1904 | 840 SF. |
| C0205 | 1104 SF. | C1005 | 1104 SF. | C1905 | 840 SF. |
| C0206 | 840 SF. | C1006 | 840 SF. | C1906 | 840 SF. |
| C0207 | 1128 SF. | C1007 | 840 SF. | C1907 | 840 SF. |
| C0208 | 492 SF. | C1008 | 492 SF. | C1908 | 492 SF. |
| C0209 | 1110 SF. | C1009 | 1110 SF. | C1909 | 1398 SF. |
| C0210 | 1120 SF. | C1010 | 1120 SF. | C1910 | 1120 SF. |
| C0211 | 288 SF. | C1011 | 288 SF. | C1911 | 288 SF. |
| C0300 | 1120 SF. | C1100 | 1612 SF. | C2000 | 1120 SF. |
| C0301 | 1398 SF. | C1101 | 1398 SF. | C2001 | 1398 SF. |
| C0302 | 492 SF. | C1102 | 840 SF. | C2002 | 492 SF. |
| C0303 | 840 SF. | C1103 | 840 SF. | C2003 | 840 SF. |
| C0304 | 840 SF. | C1104 | 840 SF. | C2004 | 840 SF. |
| C0305 | 1104 SF. | C1105 | 1104 SF. | C2005 | 840 SF. |
| C0306 | 840 SF. | C1106 | 840 SF. | C2006 | 840 SF. |
| C0307 | 840 SF. | C1107 | 840 SF. | C2007 | 840 SF. |
| C0308 | 492 SF. | C1108 | 492 SF. | C2008 | 492 SF. |
| C0309 | 1110 SF. | C1109 | 1120 SF. | C2009 | 1398 SF. |
| C0310 | 1120 SF. | C1110 | 288 SF. | C2010 | 1120 SF. |
| C0311 | 288 SF. | C1200 | 1120 SF. | C2011 | 288 SF. |
| C0400 | 1612 SF. | C1201 | 1398 SF. | C2100 | 1120 SF. |
| C0401 | 1398 SF. | C1202 | 492 SF. | C2101 | 1398 SF. |
| C0402 | 840 SF. | C1203 | 840 SF. | C2102 | 492 SF. |
| C0403 | 840 SF. | C1204 | 840 SF. | C2103 | 840 SF. |
| C0404 | 840 SF. | C1205 | 1104 SF. | C2104 | 840 SF. |
| C0405 | 1104 SF. | C1206 | 840 SF. | C2105 | 1104 SF. |
| C0406 | 840 SF. | C1207 | 1128 SF. | C2106 | 840 SF. |
| C0407 | 840 SF. | C1208 | 1110 SF. | C2107 | 840 SF. |
| C0408 | 492 SF. | C1209 | 1612 SF. | C2108 | 492 SF. |
| C0409 | 1398 SF. | C1210 | 1612 SF. | C2109 | 1398 SF. |
| C0410 | 1120 SF. | C1400 | 1120 SF. | C2110 | 1120 SF. |
| C0500 | 1120 SF. | C1401 | 1398 SF. | | |
| C0501 | 1398 SF. | C1402 | 492 SF. | | |
| C0502 | 492 SF. | C1403 | 840 SF. | | |
| C0503 | 840 SF. | C1404 | 840 SF. | | |
| C0504 | 840 SF. | C1405 | 1104 SF. | | |
| C0505 | 1104 SF. | C1406 | 840 SF. | | |
| C0506 | 840 SF. | C1407 | 840 SF. | | |
| C0507 | 840 SF. | C1408 | 492 SF. | | |
| C0508 | 492 SF. | C1409 | 1110 SF. | | |
| C0509 | 1398 SF. | C1410 | 1120 SF. | | |
| C0510 | 1120 SF. | C1500 | 1120 SF. | | |
| C0600 | 1120 SF. | C1501 | 1398 SF. | | |
| C0601 | 1398 SF. | C1502 | 492 SF. | | |
| C0602 | 492 SF. | C1503 | 840 SF. | | |
| C0603 | 840 SF. | C1504 | 840 SF. | | |
| C0604 | 840 SF. | C1505 | 1104 SF. | | |
| C0605 | 1104 SF. | C1506 | 840 SF. | | |
| C0606 | 840 SF. | C1507 | 840 SF. | | |
| C0607 | 840 SF. | C1508 | 492 SF. | | |
| C0608 | 492 SF. | C1509 | 1120 SF. | | |
| C0609 | 1110 SF. | C1510 | 1398 SF. | | |
| C0610 | 1120 SF. | C1600 | 1120 SF. | | |
| C0611 | 288 SF. | C1601 | 1398 SF. | | |
| C0700 | 1120 SF. | C1602 | 492 SF. | | |
| C0701 | 1110 SF. | C1603 | 2232 SF. | | |
| C0702 | 492 SF. | C1604 | 840 SF. | | |
| C0703 | 1128 SF. | C1605 | 840 SF. | | |
| C0704 | 840 SF. | C1606 | 840 SF. | | |
| C0705 | 1104 SF. | C1607 | 1398 SF. | | |
| C0706 | 840 SF. | C1608 | 1612 SF. | | |
| C0707 | 840 SF. | C1609 | 1120 SF. | | |
| C0708 | 492 SF. | C1610 | 1398 SF. | | |
| C0709 | 1398 SF. | C1611 | 492 SF. | | |
| C0710 | 1120 SF. | C1612 | 840 SF. | | |
| C0800 | 1120 SF. | C1700 | 840 SF. | | |
| C0801 | 1110 SF. | C1701 | 1104 SF. | | |
| C0802 | 492 SF. | C1702 | 840 SF. | | |
| C0803 | 840 SF. | C1703 | 1128 SF. | | |
| C0804 | 840 SF. | C1704 | 1110 SF. | | |
| C0805 | 840 SF. | C1705 | 1612 SF. | | |
| C0806 | 840 SF. | C1706 | 1120 SF. | | |
| C0807 | 1128 SF. | C1707 | 1398 SF. | | |
| C0808 | 492 SF. | C1708 | 492 SF. | | |
| C0809 | 1110 SF. | C1709 | 840 SF. | | |
| C0810 | 1120 SF. | C1710 | 840 SF. | | |
| C0811 | 288 SF. | C1800 | 1104 SF. | | |
| C0900 | 1120 SF. | C1801 | 840 SF. | | |
| C0901 | 1398 SF. | C1802 | 840 SF. | | |
| C0902 | 492 SF. | C1803 | 492 SF. | | |
| C0903 | 840 SF. | C1804 | 1110 SF. | | |
| C0904 | 840 SF. | C1805 | 1120 SF. | | |
| C0905 | 1104 SF. | C1806 | 288 SF. | | |
| C0906 | 840 SF. | | | | |
| C0907 | 1128 SF. | | | | |
| C0908 | 492 SF. | | | | |
| C0909 | 1110 SF. | | | | |
| C0910 | 1120 SF. | | | | |

"THIS TAX MAP SHEET HAS BEEN DIGITALLY REVISED USING COMPUTER-AIDED DRAFTING/DESIGN (CADD) & COORDINATE GEOMETRY (COGO). IT IS BASED ON THE ORIGINAL DIGITALLY DRAWN TAX MAP PLATE BEARING THE OFFICIAL NEW JERSEY DIVISION TAXATION APPROVAL STAMP WITH APPROVAL DATE JULY, 20, 2016. SERIAL NUMBER 1070 AND SIGNATURE OF JUDY P. MILLER, CTA, CHIEF PROPERTY ADMINISTRATION AND SHELLY REILLY, CTA, PRINCIPAL FIELD REPRESENTATIVE. THE ORIGINAL DIGITALLY DRAWN TAX MAP PLATE WITH THE OFFICIAL APPROVAL STAMP IS ON FILE WITH REMINGTON & VERNICK ENGINEERS."

**TAX MAP
CITY OF VENTNOR**

ATLANTIC COUNTY NEW JERSEY
SCALE: NOTED DATE: 2-19-2015

CHARLES E. ADAMSON NJ PROFESSIONAL LAND SURVEYOR LIC. NO. 42627
24 GA 28048700
REMINGTON, VERNICK & WALBERG ENGINEERS
845 N. MAIN STREET, PLEASANTVILLE, NJ 08232
(609) 645-700, FAX (609) 645-7076
WEB SITE ADDRESS: WWW.RVE.COM
TO SHOW CONDITIONS AS OF 2-10-2021