

REVISIONS		
DATE	NAME	NO.

NOTE:
THIS SHEET HAS BEEN DRAWN USING COMPUTER AIDED DRAFTING/DESIGN (CADD) AND COORDINATE GEOMETRY (COGO).

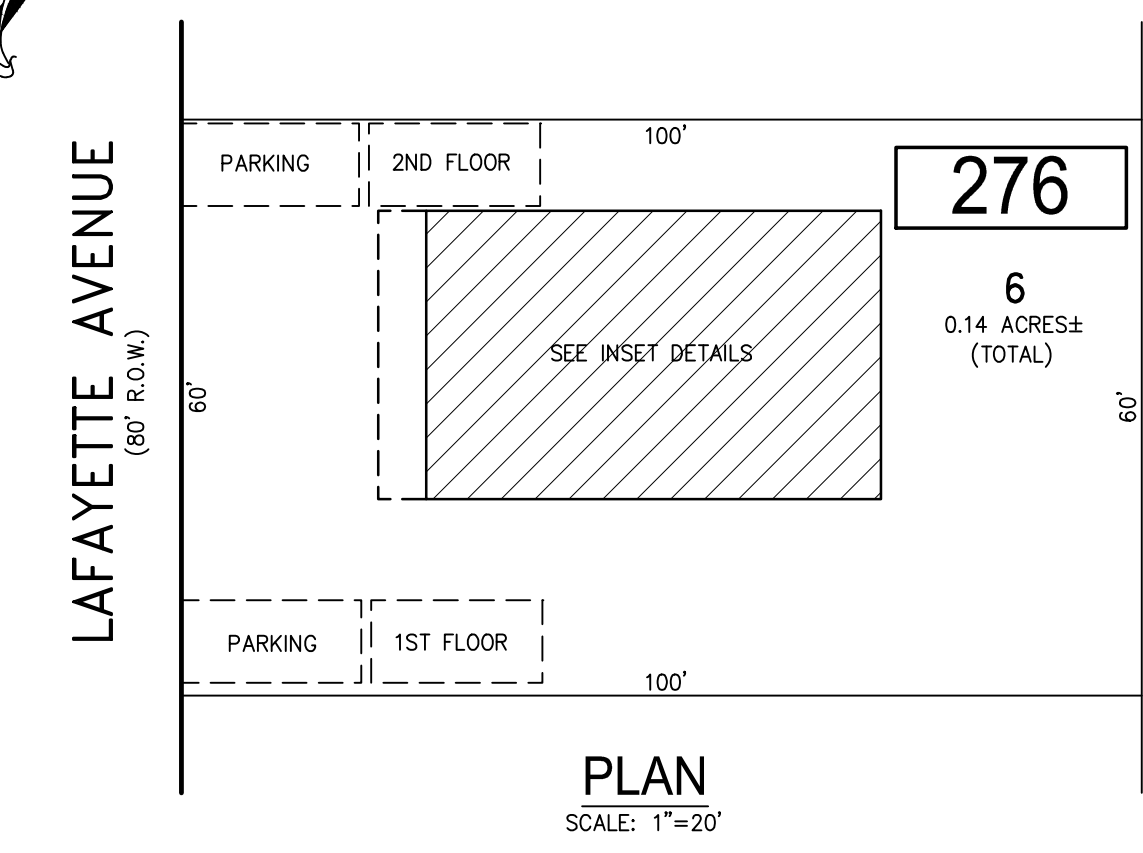

PLAN
SCALE: 1"=20'

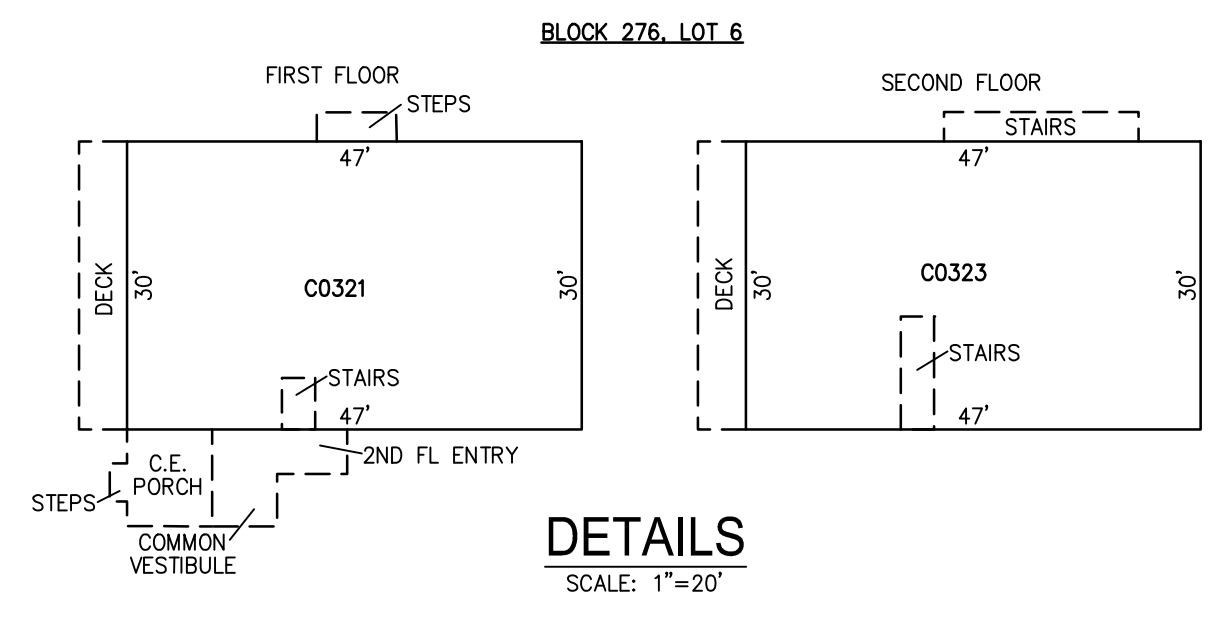

DETAILS
SCALE: 1"=20'

CONDO QUALIFIER	SQUARE FOOTAGE
C0321	1410 SF.
C0323	1410 SF.

BLOCK 276, LOT 6
321-23 LAFAYETTE AVENUE CONDOMINIUM

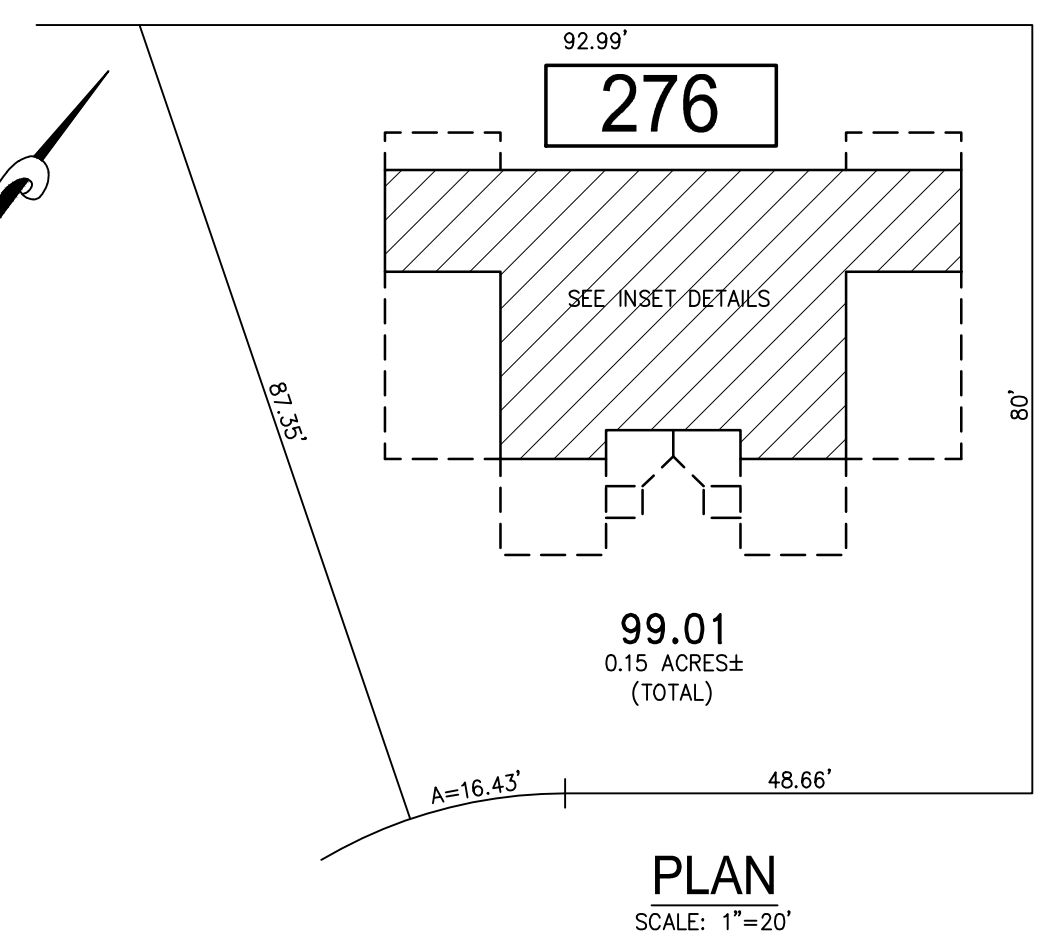

PLAN
SCALE: 1"=20'

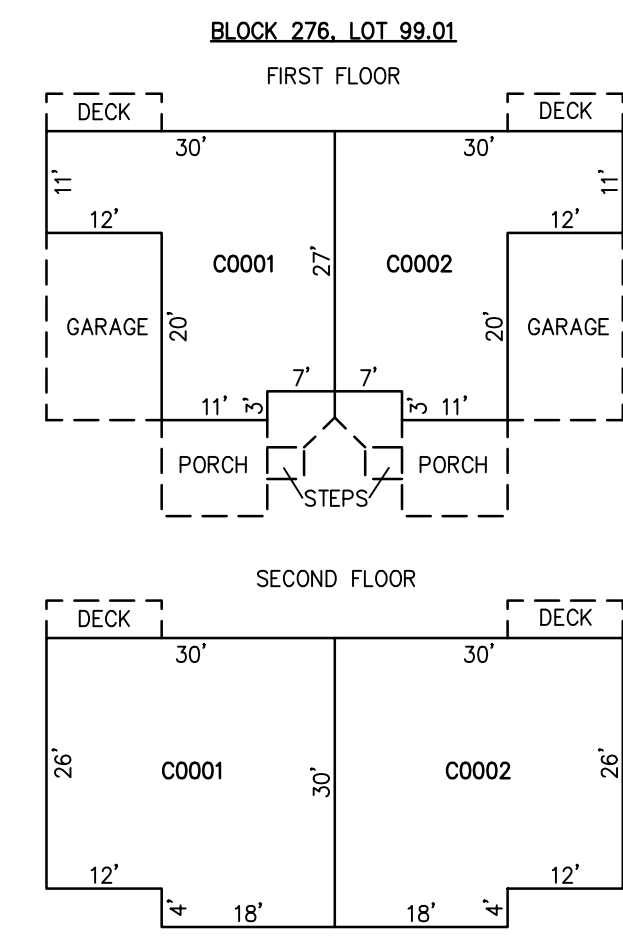

DETAILS
SCALE: 1"=20'

CONDO QUALIFIER	SQUARE FOOTAGE
C0001	1518 SF.
C0002	1518 SF.

BLOCK 276, LOT 99.01
422 CANTERBURY COURT CONDOMINIUM

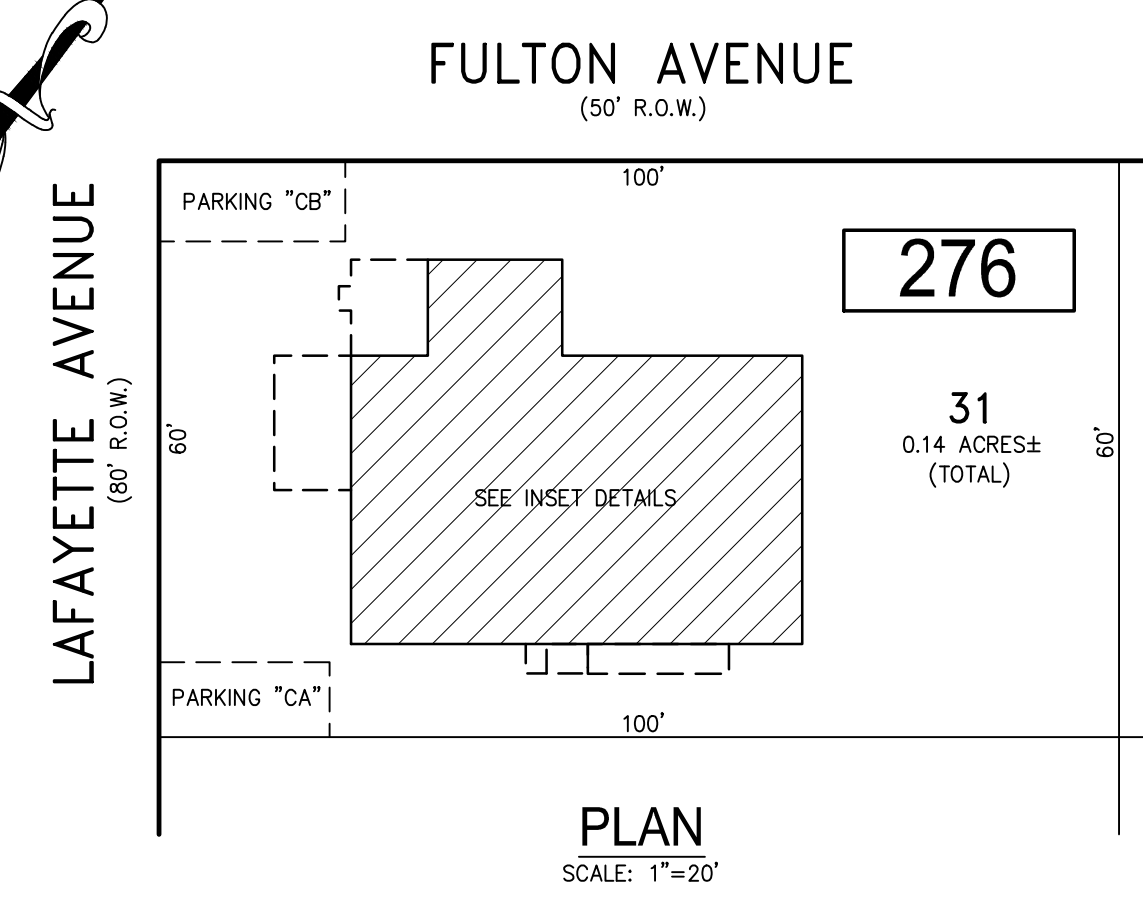

PLAN
SCALE: 1"=20'

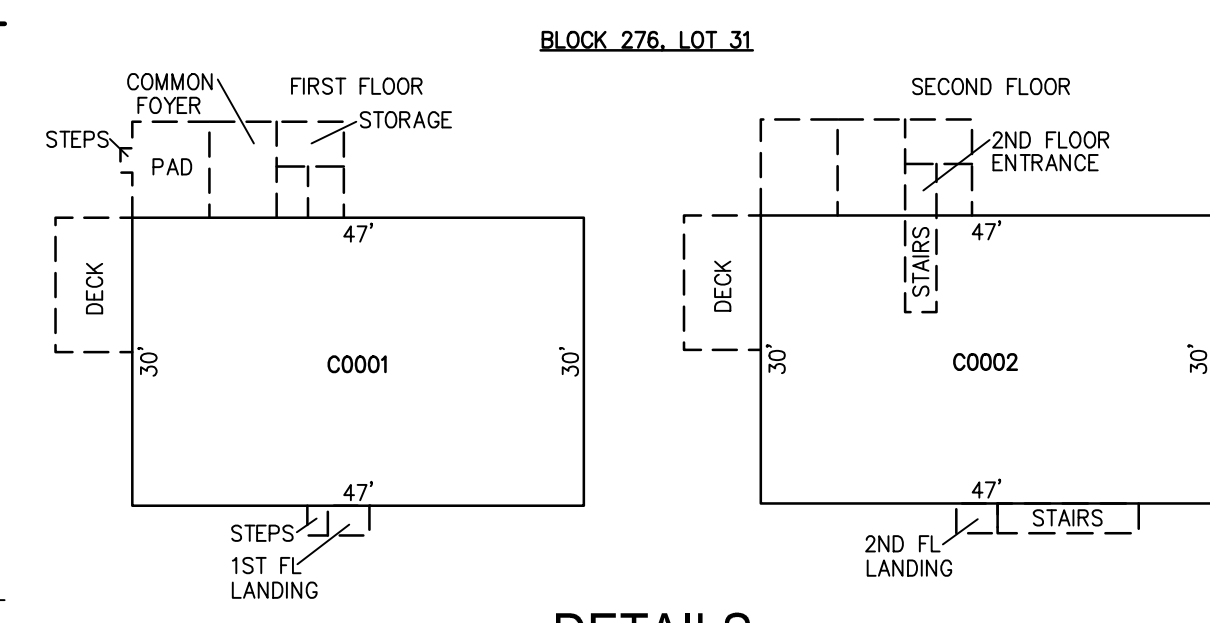

DETAILS
SCALE: 1"=20'

CONDO QUALIFIER	SQUARE FOOTAGE
C0001	1557 SF.
C0002	1557 SF.

BLOCK 276, LOT 31
421-23 LAFAYETTE AVENUE CONDOMINIUM

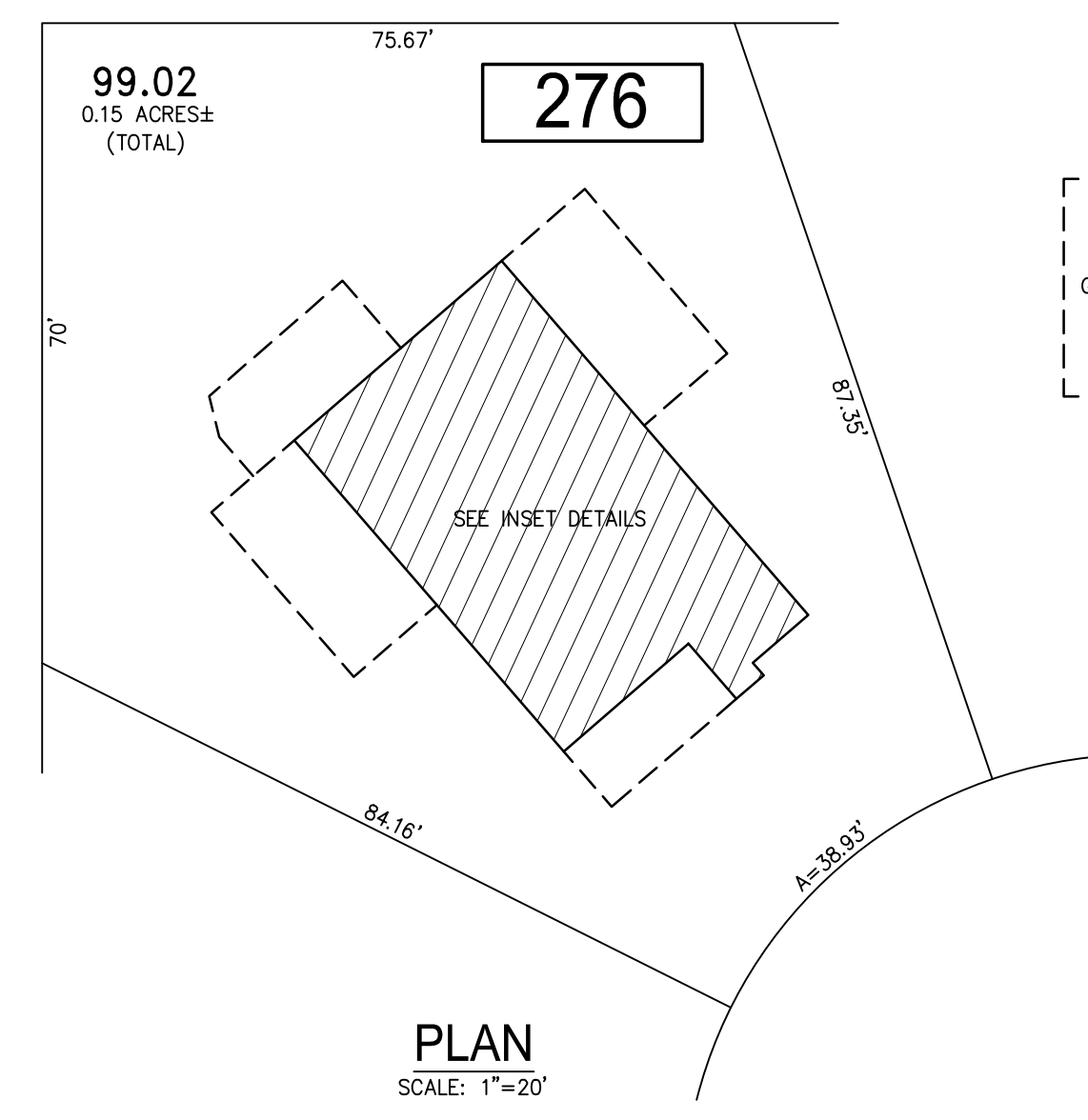

PLAN
SCALE: 1"=20'

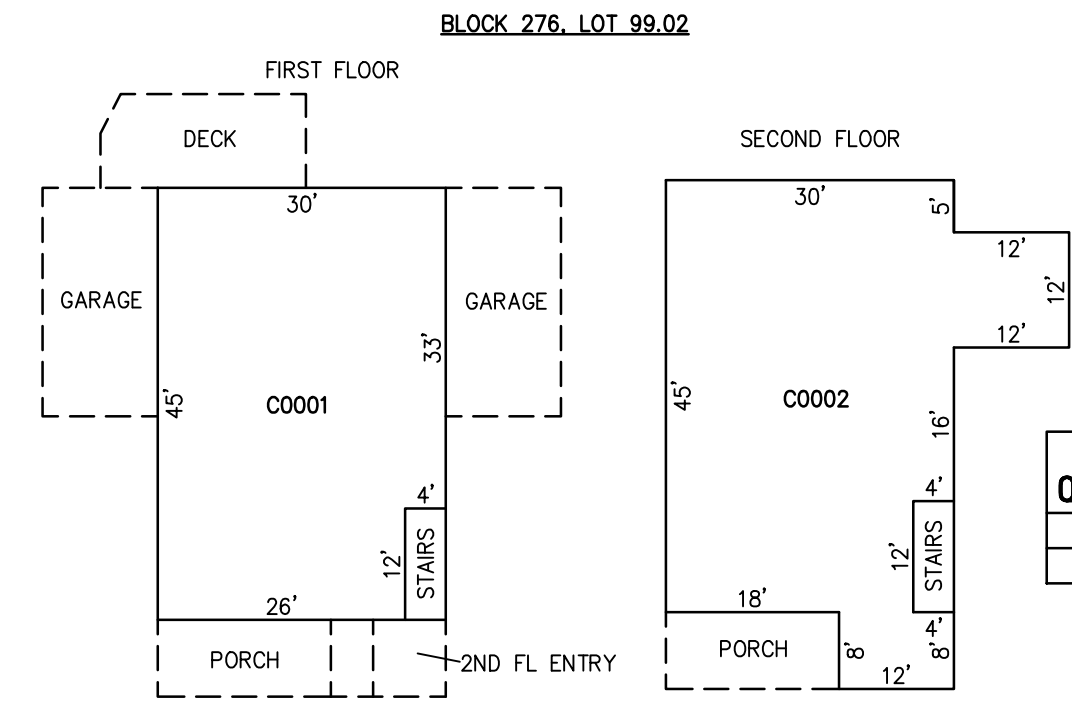

DETAILS
SCALE: 1"=20'

CONDO QUALIFIER	SQUARE FOOTAGE
C0001	1385 SF.
C0002	1476 SF.

BLOCK 276, LOT 99.02
424 CANTERBURY COURT CONDOMINIUM

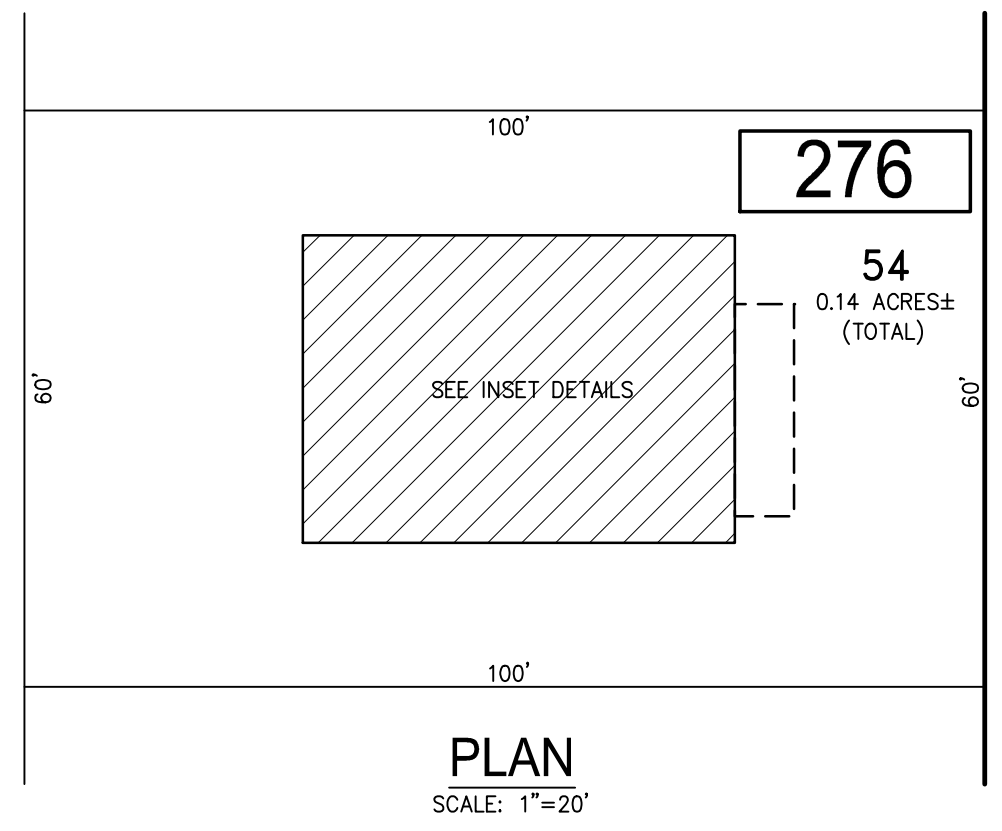

PLAN
SCALE: 1"=20'

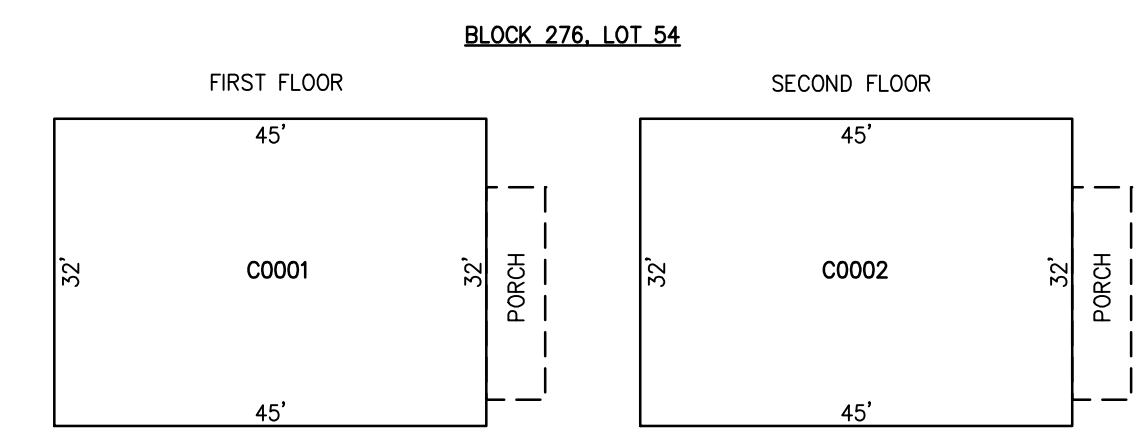

DETAILS
SCALE: 1"=20'

CONDO QUALIFIER	SQUARE FOOTAGE
C0001	1419 SF.
C0002	1419 SF.

BLOCK 276, LOT 54
404-06 N. WISSAHICKON AVENUE CONDOMINIUM

BLOCK 276, LOT 6
BLOCK 276, LOT 31
BLOCK 276, LOT 54
BLOCK 276, LOT 99.01
BLOCK 276, LOT 99.02
SEE SHEET 44

"THIS TAX MAP SHEET HAS BEEN DIGITALLY REVISED USING COMPUTER-AIDED DRAFTING/DESIGN (CADD) & COORDINATE GEOMETRY (COGO). IT IS BASED ON THE ORIGINAL DIGITALLY DRAWN TAX MAP PLATE BEARING THE OFFICIAL NEW JERSEY DIVISION TAXATION APPROVAL STAMP WITH APPROVAL DATE JULY, 20, 2016. SERIAL NUMBER 1070 AND SIGNATURE OF JUDY P. MILLER, CTA, CHIEF PROPERTY ADMINISTRATION AND SHELLY REILLY, CTA, PRINCIPAL FIELD REPRESENTATIVE. THE ORIGINAL DIGITALLY DRAWN TAX MAP PLATE WITH THE OFFICIAL APPROVAL STAMP IS ON FILE WITH REMINGTON & VERNICK ENGINEERS."

TAX MAP
CITY OF VENTNOR
ATLANTIC COUNTY NEW JERSEY
SCALE: NOTED DATE: 2-19-2015

CHARLES E. ADAMSON NJ PROFESSIONAL LAND SURVEYOR LIC. NO. 42627
24 GA 28048700

RV & W REMINGTON, VERNICK & WALBERG ENGINEERS
845 N. MAIN STREET, PLEASANTVILLE, NJ 08232
(609) 645-700, FAX (609) 645-7076
WEB SITE ADDRESS: WWW.RVE.COM
TO SHOW CONDITIONS AS OF 2-10-2021