

REVISIONS		
DATE	NAME	NO.

NOTE:
THIS SHEET HAS BEEN DRAWN USING COMPUTER AIDED DRAFTING/DESIGN (CADD) AND COORDINATE GEOMETRY (COGO).

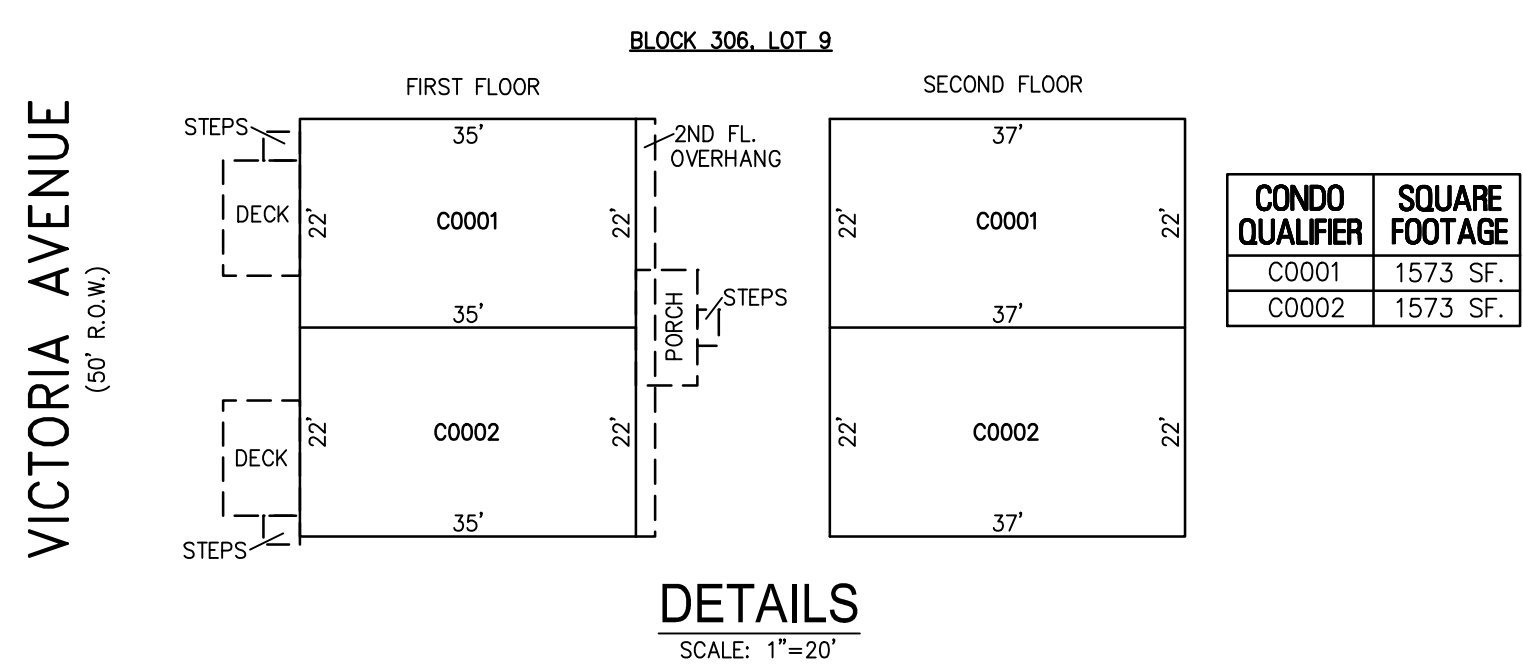
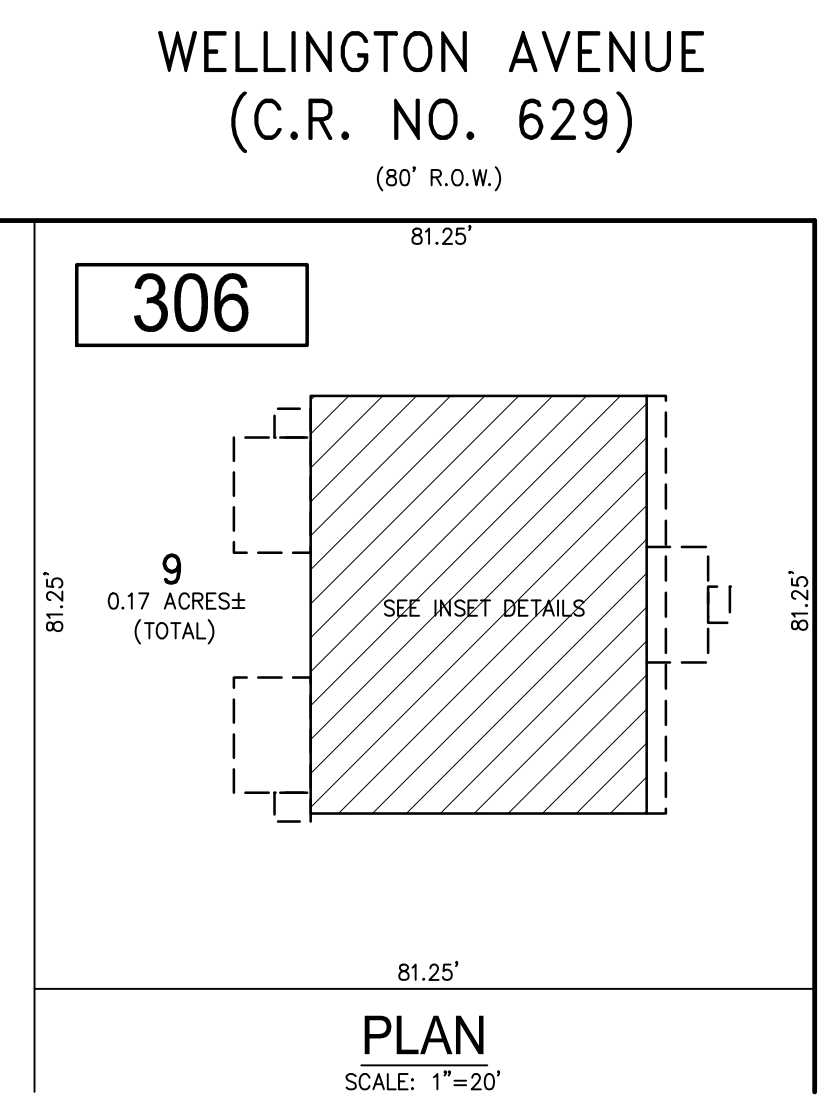

PLAN
SCALE: 1"=20'

BLOCK 306, LOT 9
THE VICTORIA IX CONDOMINIUM
610 N. VICTORIA AVENUE

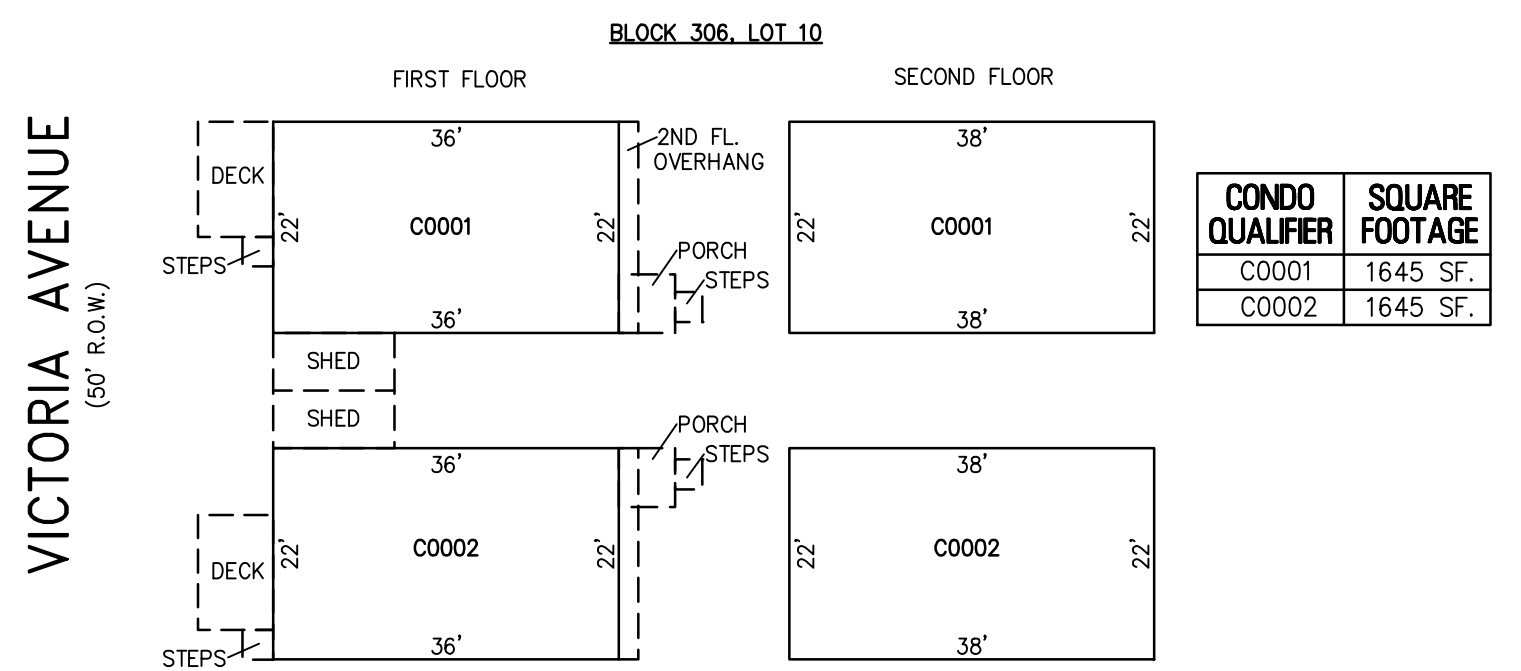
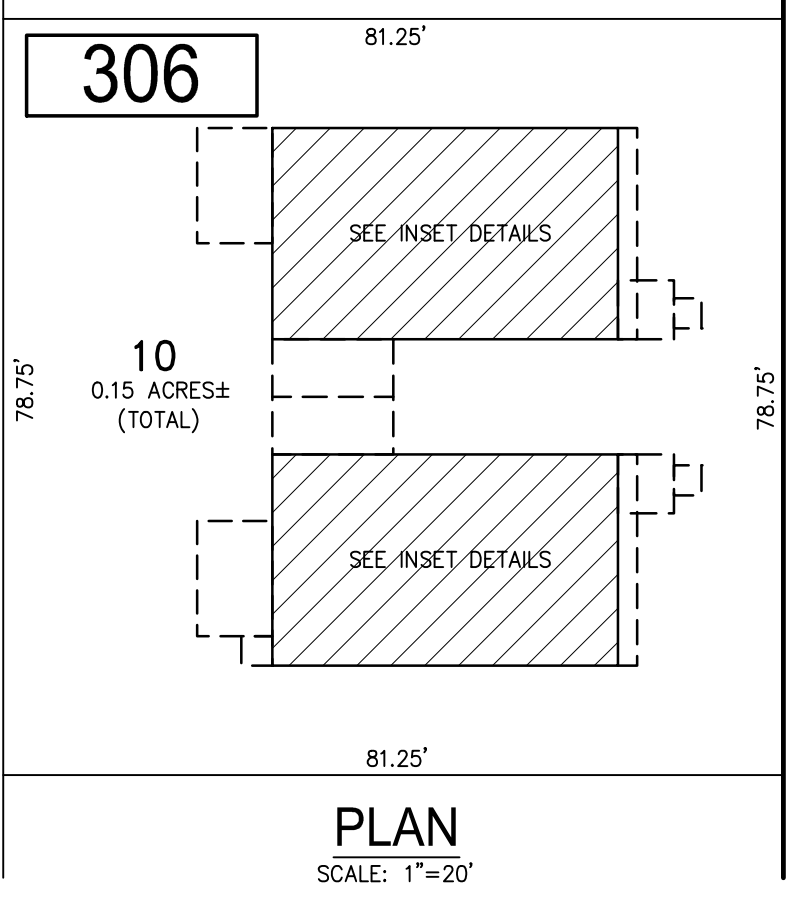

PLAN
SCALE: 1"=20'

BLOCK 306, LOT 10
THE VICTORIA X CONDOMINIUM
608 N. VICTORIA AVENUE

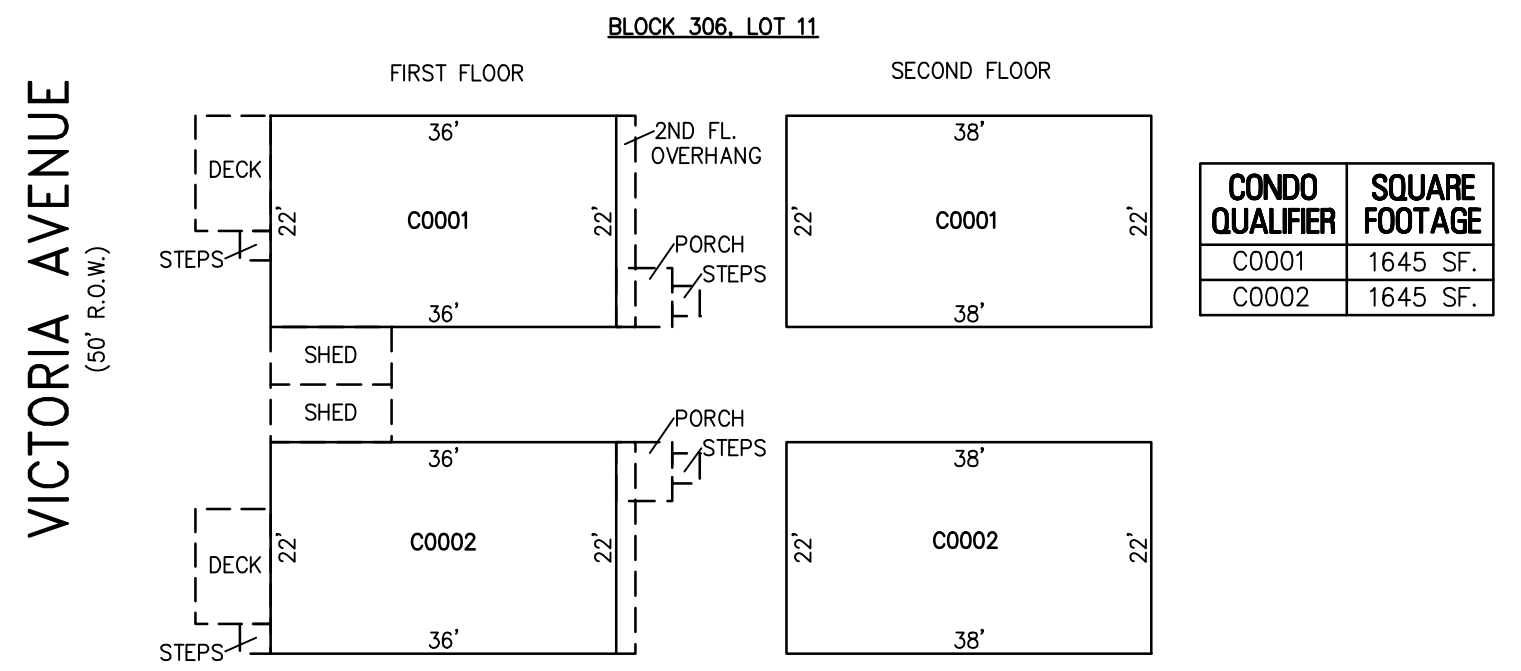
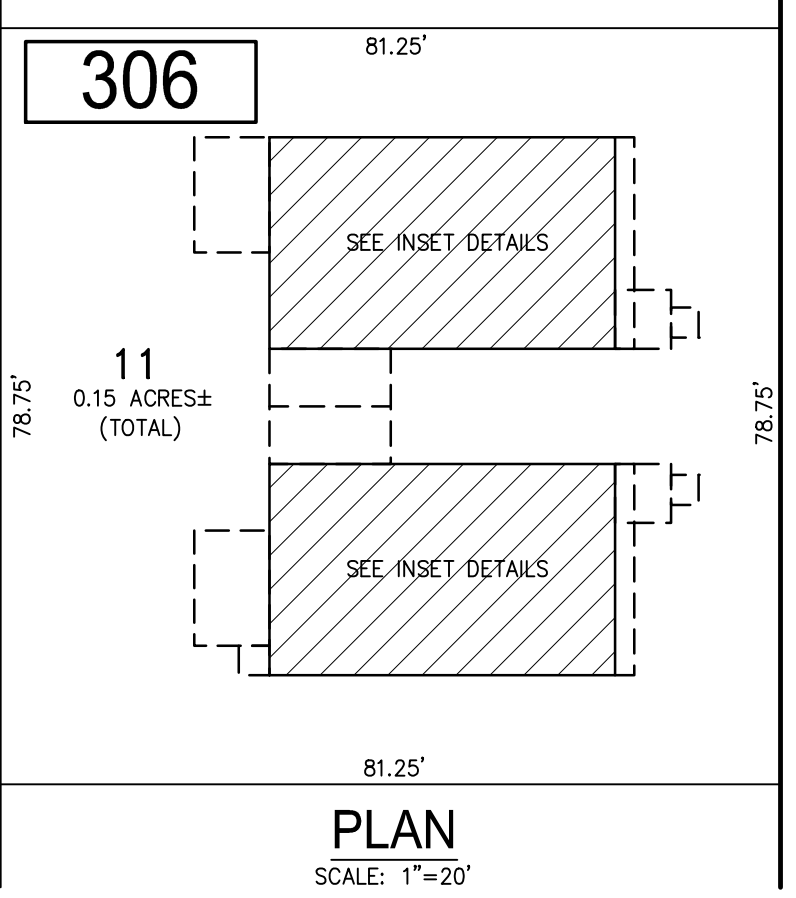

PLAN
SCALE: 1"=20'

BLOCK 306, LOT 11
THE VICTORIA XI CONDOMINIUM
606 N. VICTORIA AVENUE

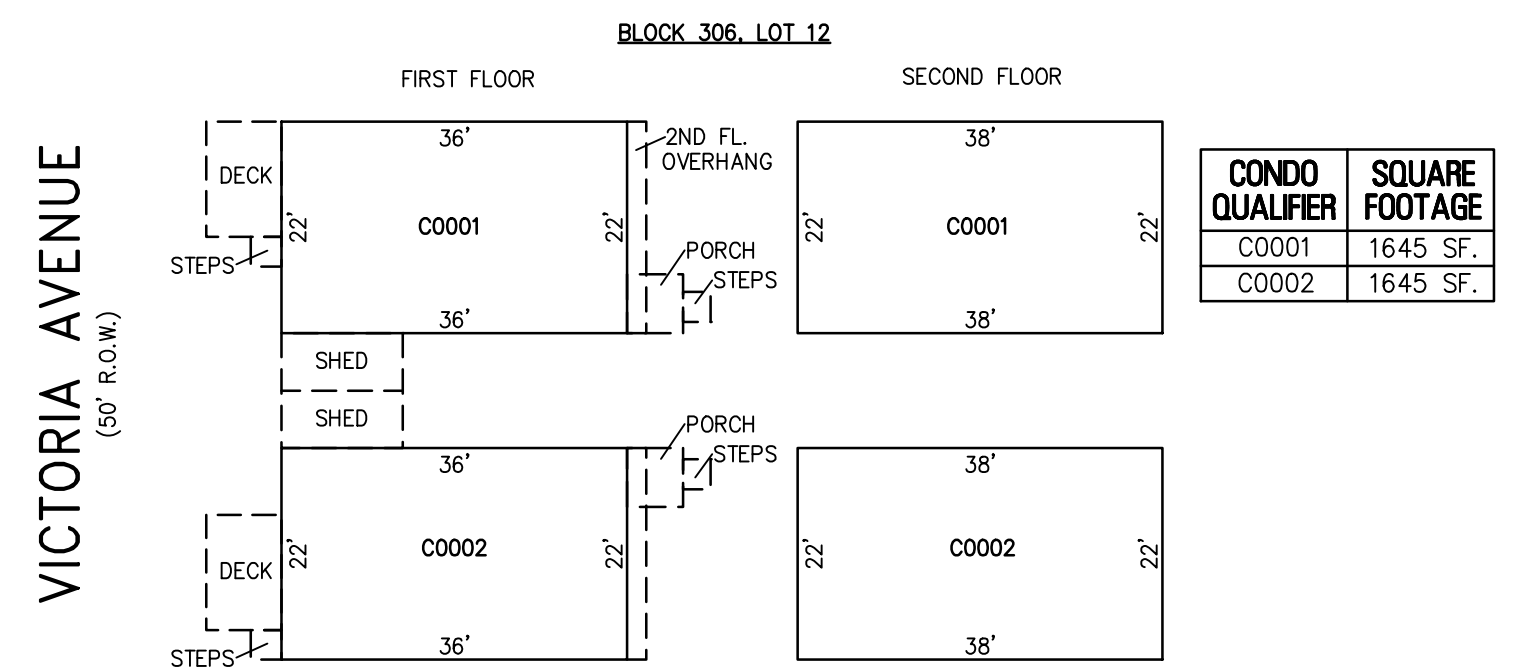
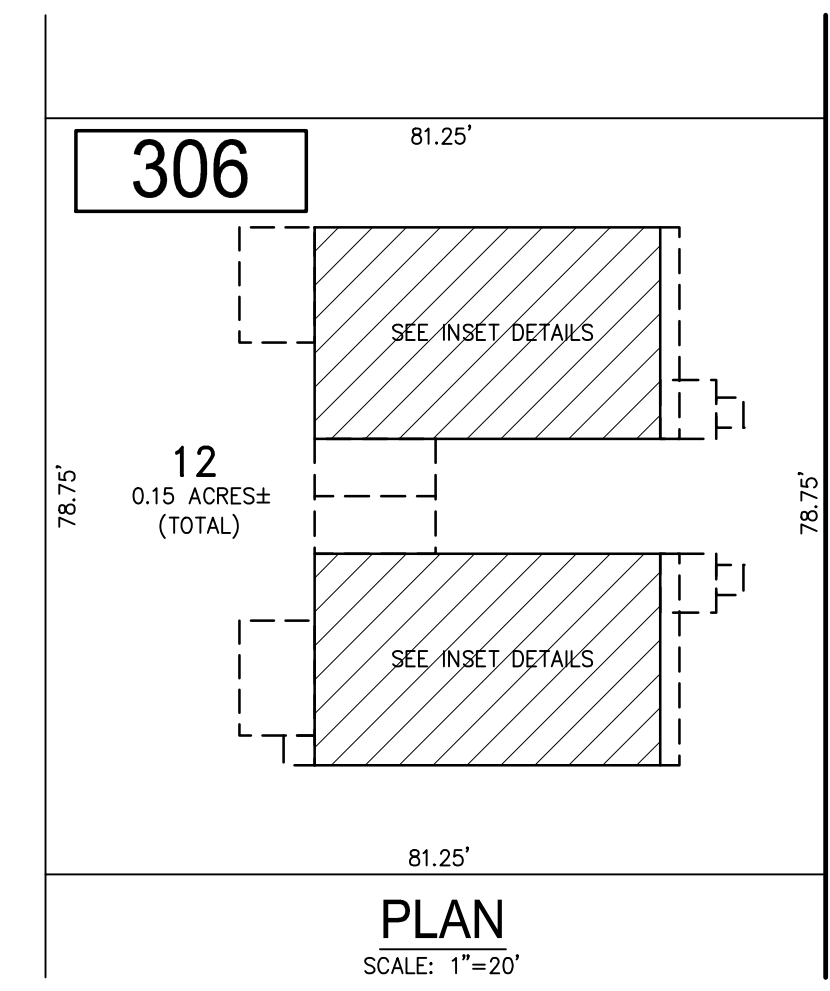

PLAN
SCALE: 1"=20'

BLOCK 306, LOT 12
THE VICTORIA XII CONDOMINIUM
604 N. VICTORIA AVENUE

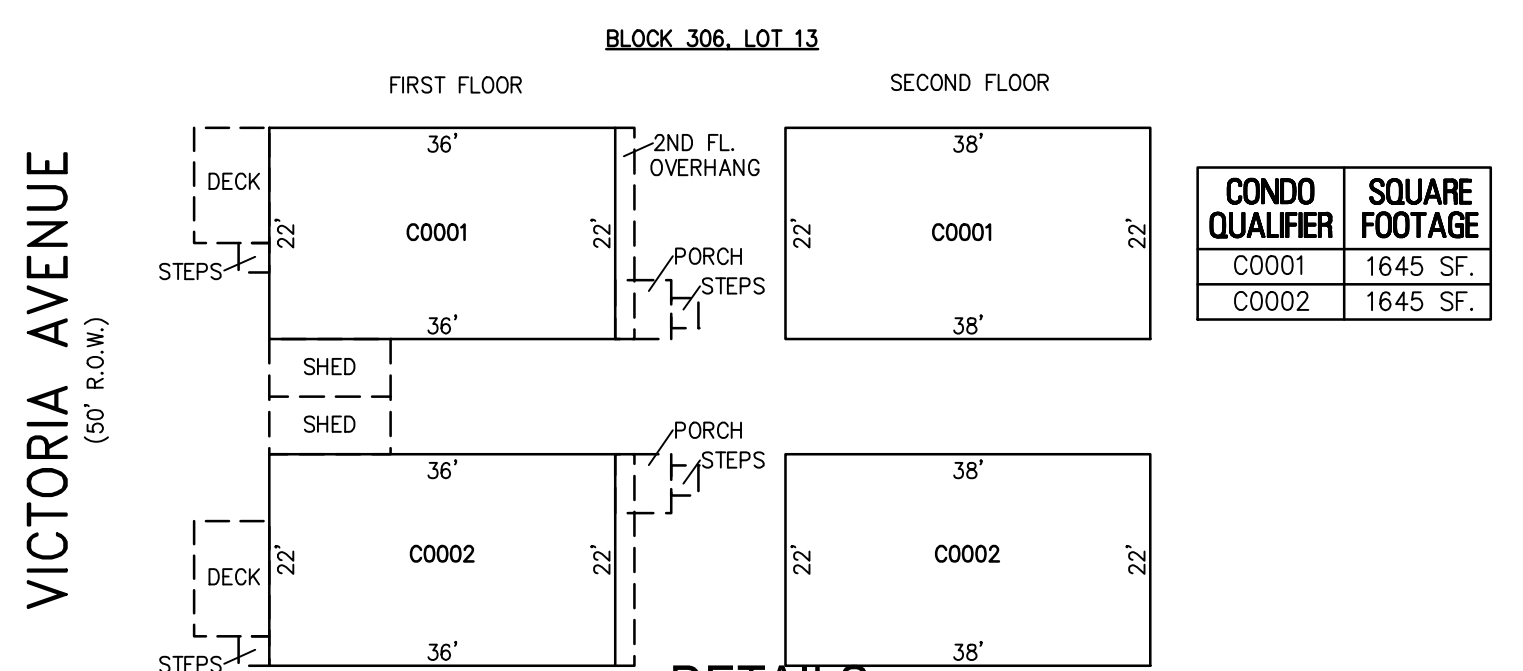
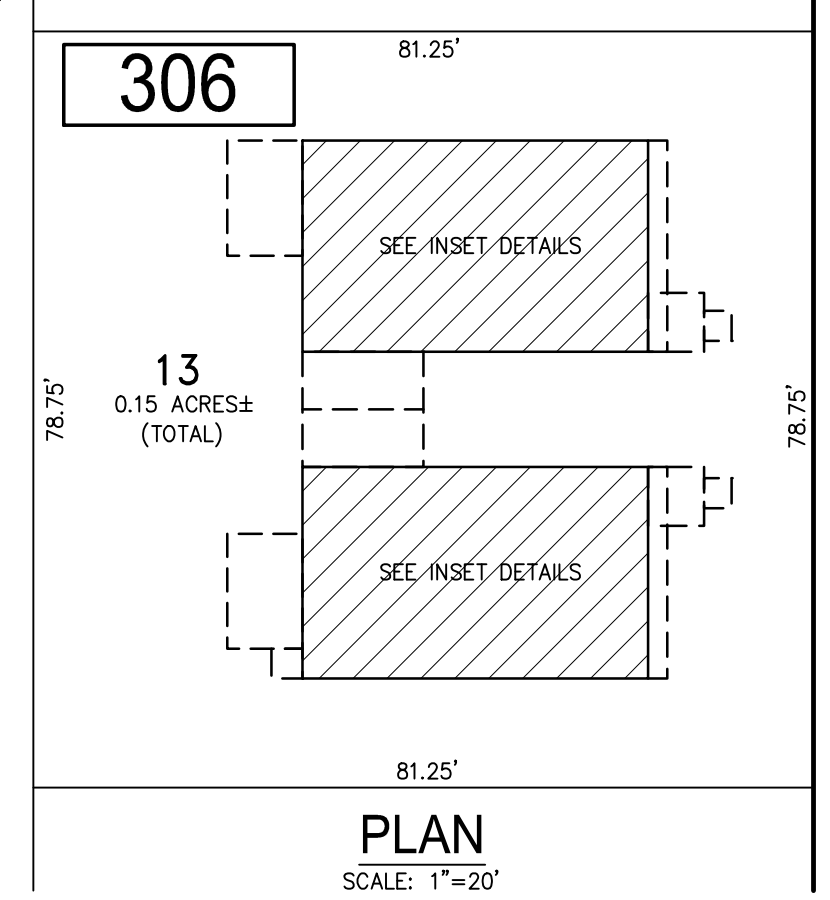

PLAN
SCALE: 1"=20'

BLOCK 306, LOT 13
THE VICTORIA XIII CONDOMINIUM
602 N. VICTORIA AVENUE

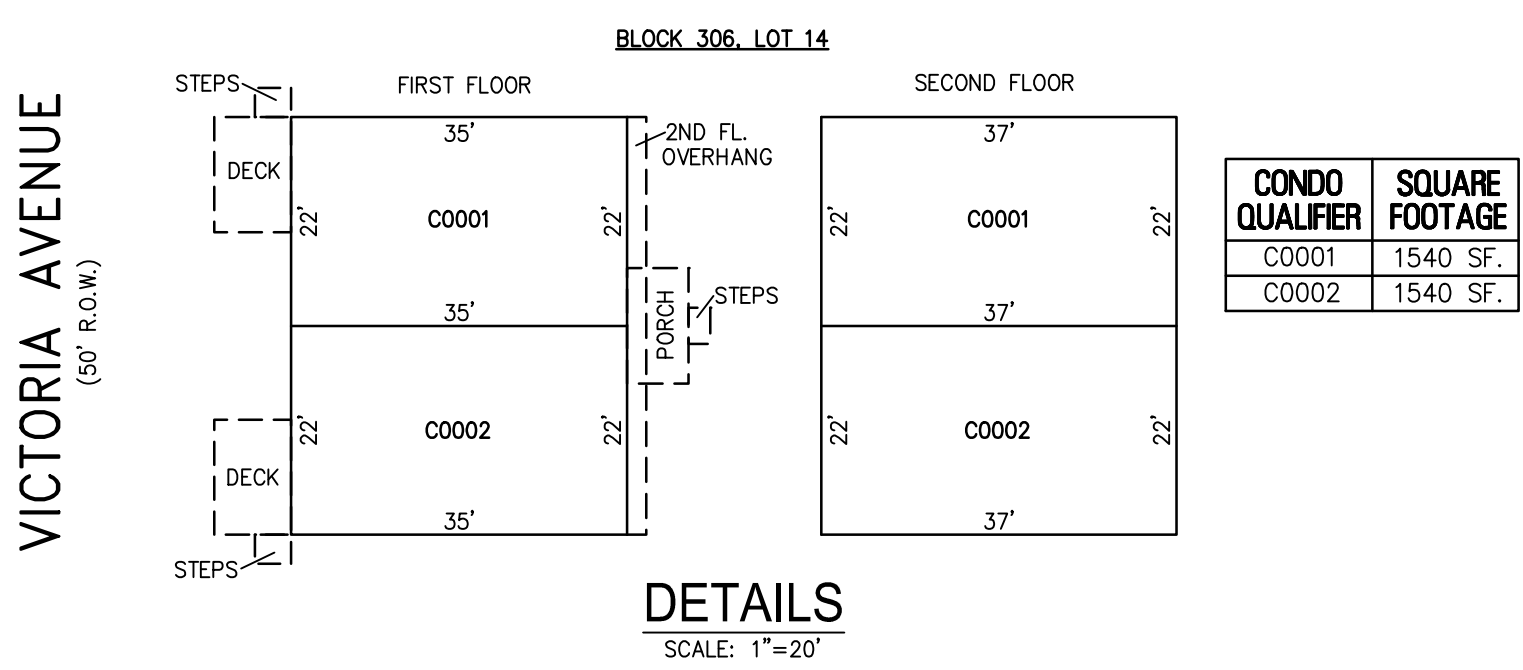
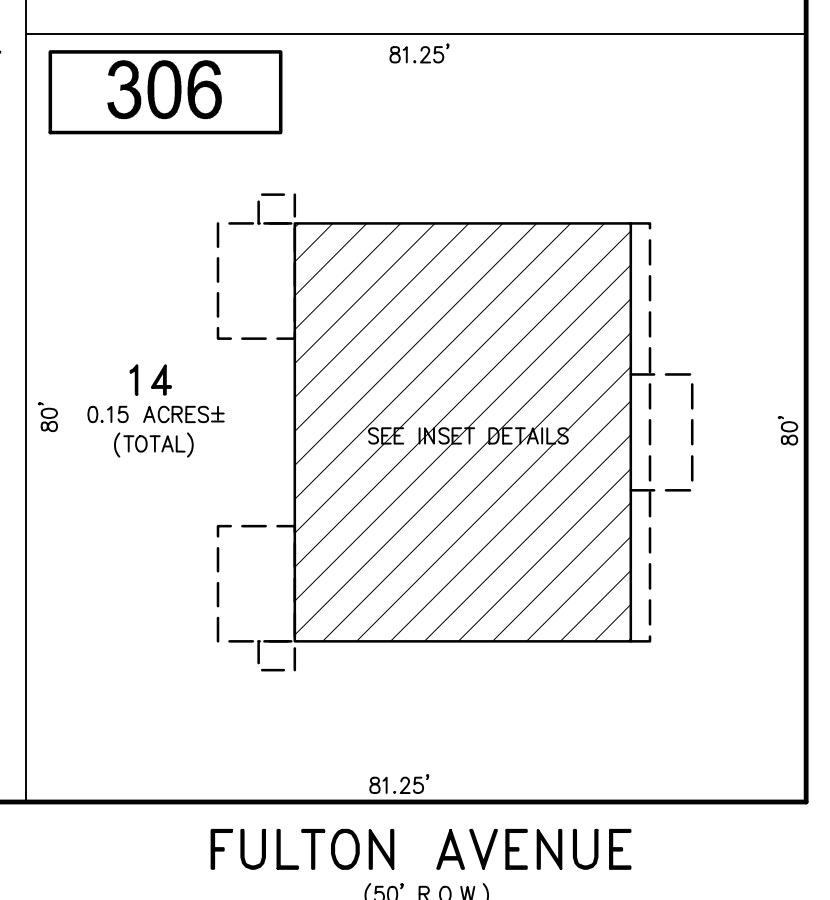

PLAN
SCALE: 1"=20'

BLOCK 306, LOT 14
THE VICTORIA XIV CONDOMINIUM
600 N. VICTORIA AVENUE

- BLOCK 306, LOT 9
- BLOCK 306, LOT 10
- BLOCK 306, LOT 11
- BLOCK 306, LOT 12
- BLOCK 306, LOT 13
- BLOCK 306, LOT 14
- SEE SHEET 50

"THIS TAX MAP SHEET HAS BEEN DIGITALLY REVISED USING COMPUTER-AIDED DRAFTING/DESIGN (CADD) & COORDINATE GEOMETRY (COGO). IT IS BASED ON THE ORIGINAL DIGITALLY DRAWN TAX MAP PLATE BEARING THE OFFICIAL NEW JERSEY DIVISION TAXATION APPROVAL STAMP WITH APPROVAL DATE JULY, 20, 2016. SERIAL NUMBER 1070 AND SIGNATURE OF JUDY P. MILLER, C.T.A. CHIEF PROPERTY ADMINISTRATION AND SHELLY REILLY, C.T.A. PRINCIPAL FIELD REPRESENTATIVE. THE ORIGINAL DIGITALLY DRAWN TAX MAP PLATE WITH THE OFFICIAL APPROVAL STAMP IS ON FILE WITH REMINGTON & VERNICK ENGINEERS."

TAX MAP
CITY OF VENTNOR
ATLANTIC COUNTY NEW JERSEY
SCALE: NOTED DATE: 2-19-2015

CHARLES E. ADAMSON NJ PROFESSIONAL LAND SURVEYOR LIC. NO. 42627
24 GA 28048700

RV & W **REMINGTON, VERNICK & WALBERG ENGINEERS**
845 N. MAIN STREET, PLEASANTVILLE, NJ 08232
(609) 645-700, FAX (609) 645-7076
WEB SITE ADDRESS: WWW.RVW.COM
TO SHOW CONDITIONS AS OF 2-10-2021