

REVISIONS		
DATE	NAME	NO.

NOTE:
THIS SHEET HAS BEEN DRAWN USING COMPUTER AIDED DRAFTING/DESIGN (CADD) AND COORDINATE GEOMETRY (COGO).

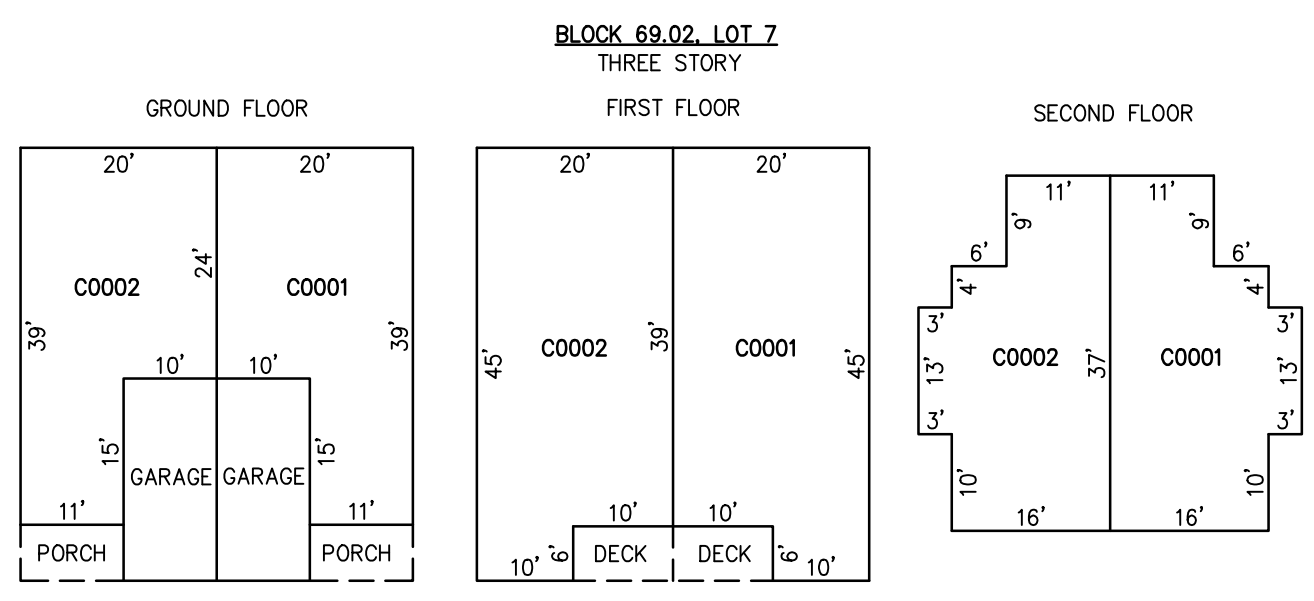
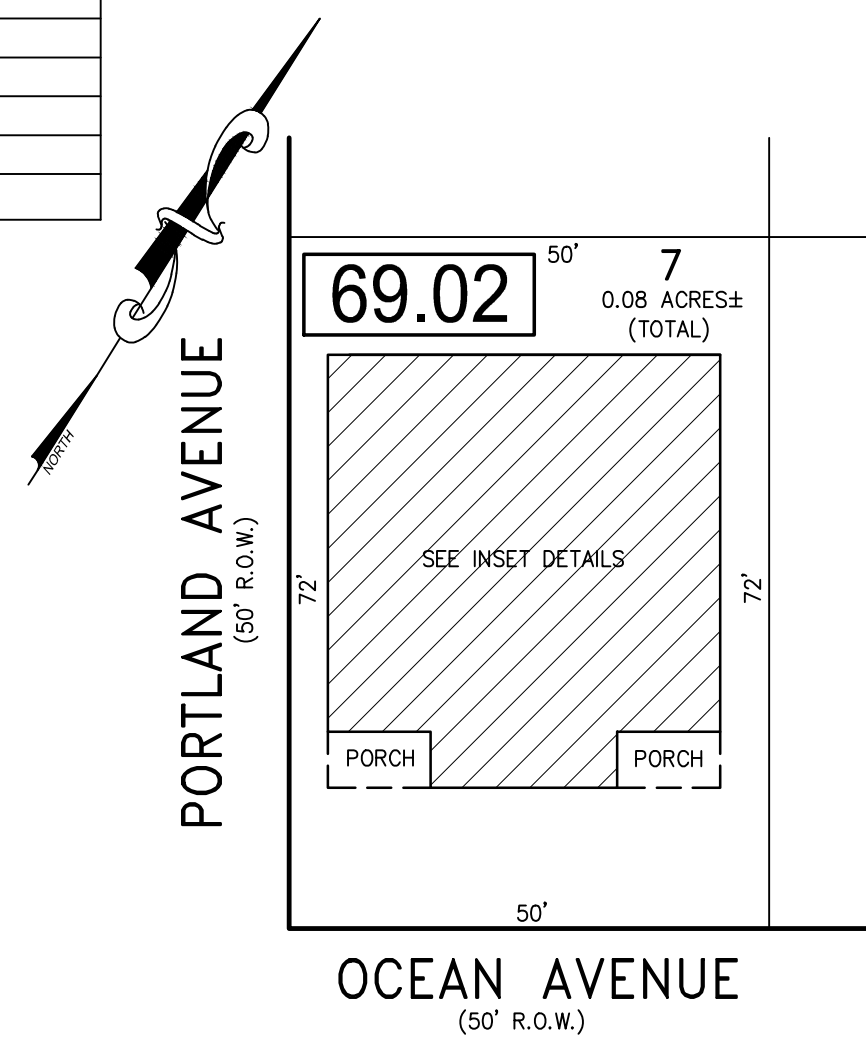

CONDO QUALIFIER	SQUARE FOOTAGE
C0001	2080 SF.
C0002	2080 SF.

DETAILS
SCALE: 1"=20'

BLOCK 69.02, LOT 7
OCEAN VILLA 6321-6323 OCEAN AVENUE CONDOMINIUM

PLAN
SCALE: 1"=20'

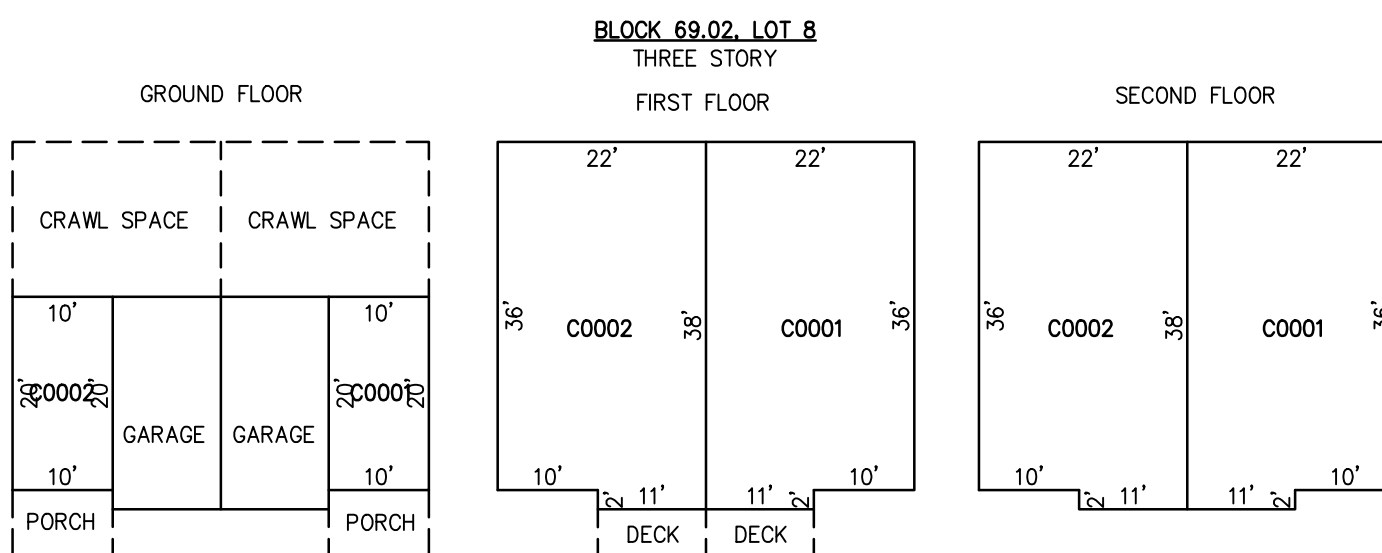
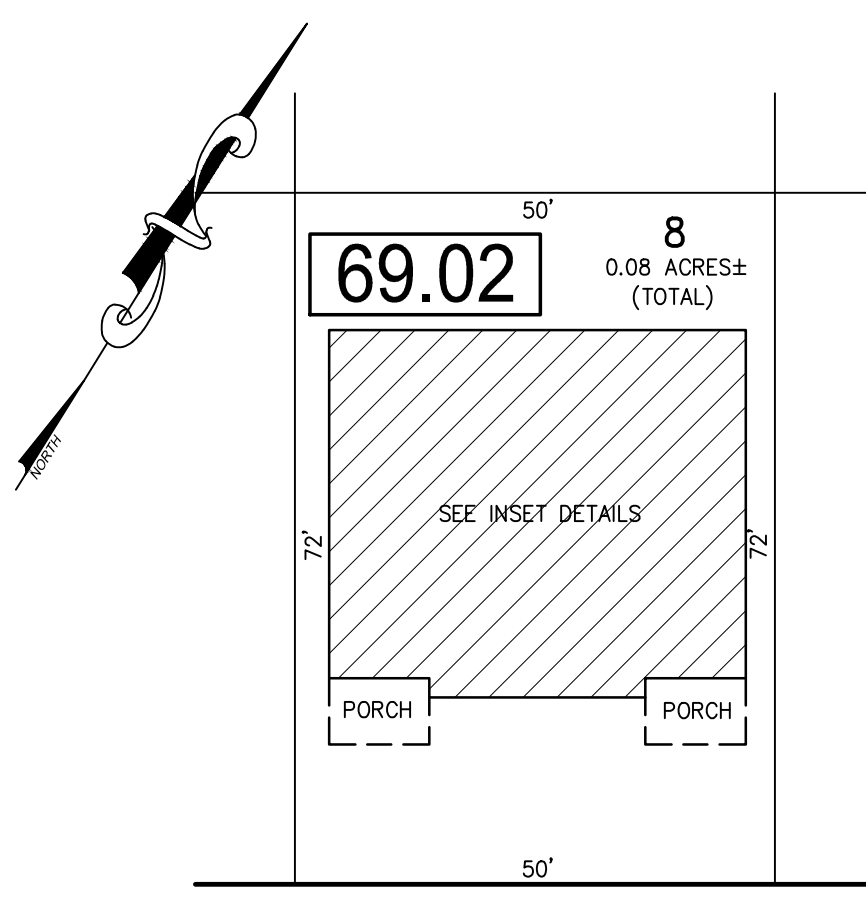

CONDO QUALIFIER	SQUARE FOOTAGE
C0001	1800 SF.
C0002	1800 SF.

DETAILS
SCALE: 1"=20'

BLOCK 69.02, LOT 8
OCEAN VILLA 6317-6319 OCEAN AVENUE CONDOMINIUM

PLAN
SCALE: 1"=20'

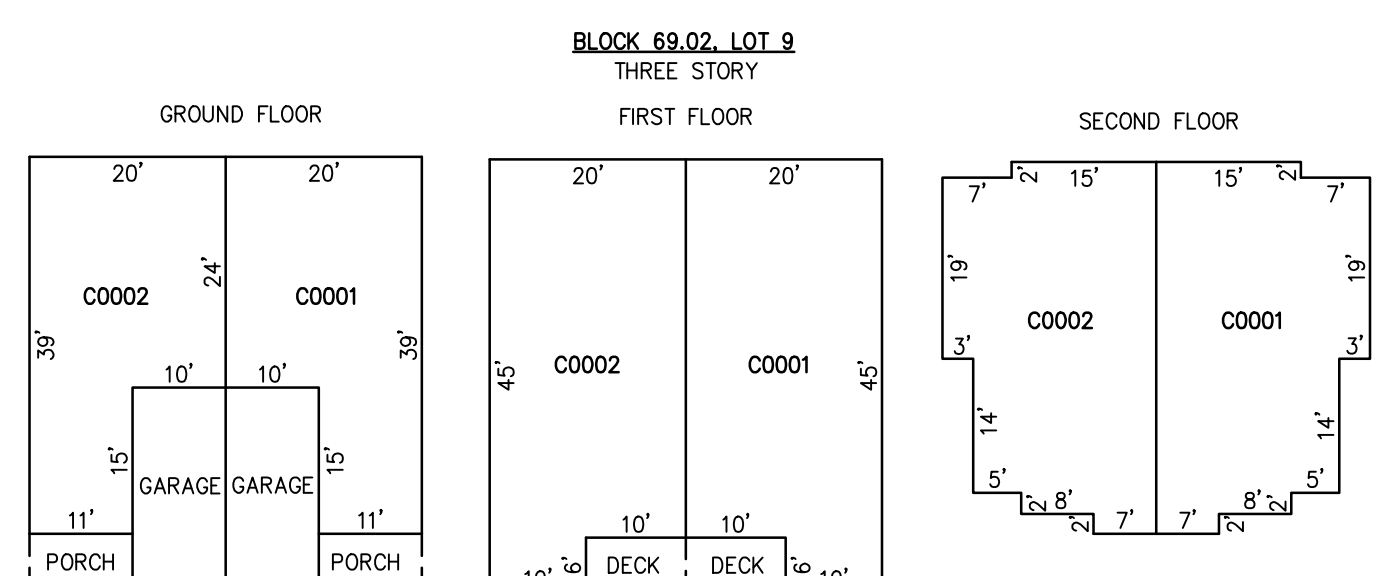
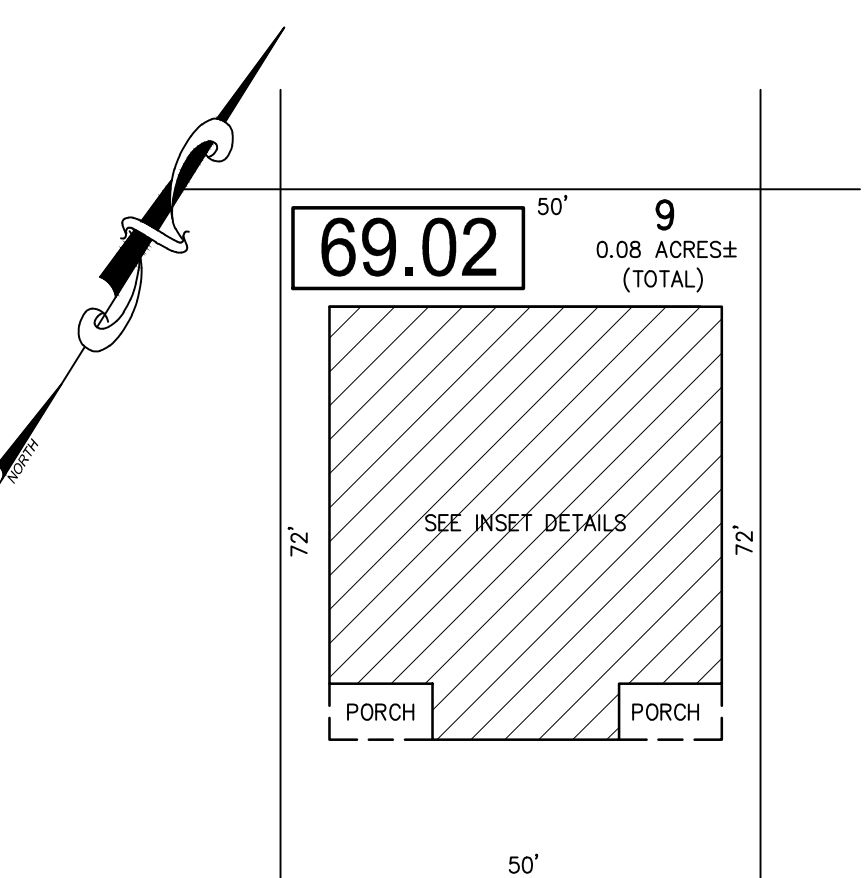

CONDO QUALIFIER	SQUARE FOOTAGE
C0001	2080 SF.
C0002	2080 SF.

DETAILS
SCALE: 1"=20'

BLOCK 69.02, LOT 9
OCEAN VILLA 6313-6315 OCEAN AVENUE CONDOMINIUM

PLAN
SCALE: 1"=20'

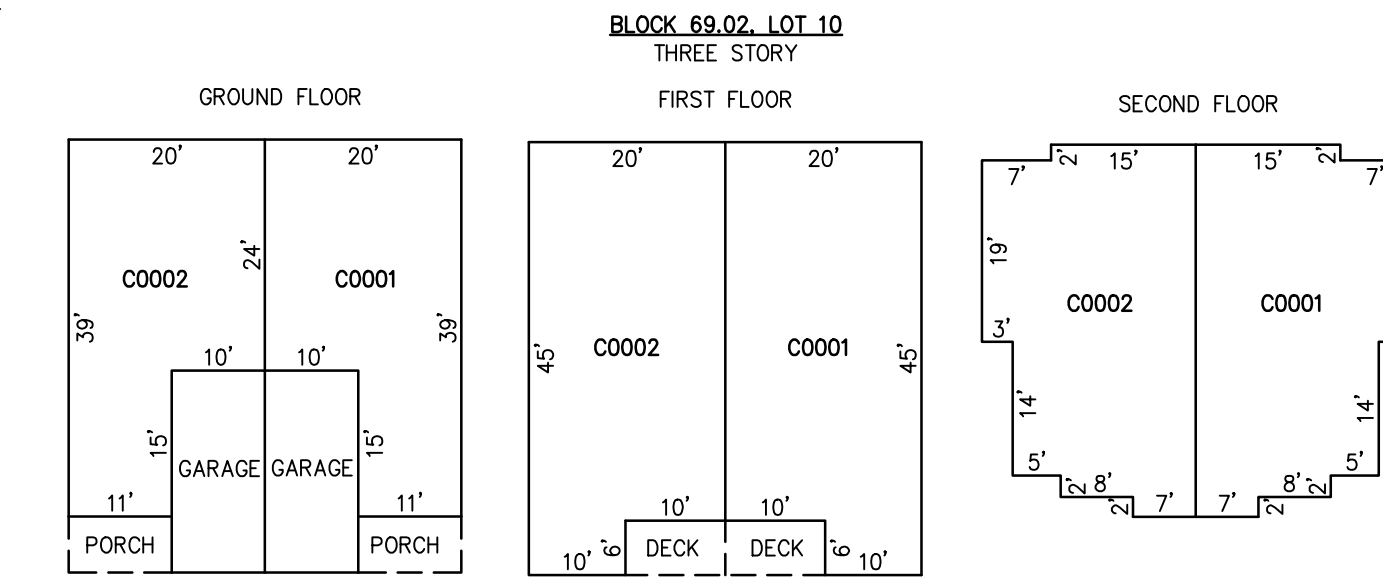
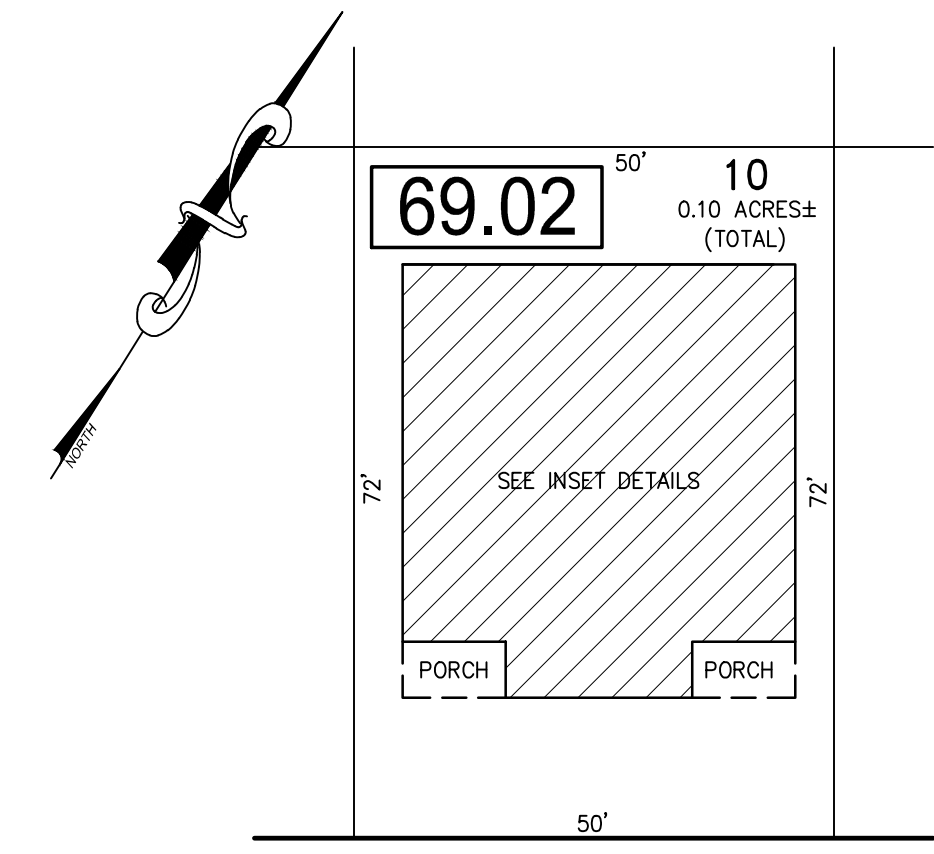

CONDO QUALIFIER	SQUARE FOOTAGE
C0001	2083 SF.
C0002	2083 SF.

DETAILS
SCALE: 1"=20'

BLOCK 69.02, LOT 10
OCEAN VILLA 6309-6311 OCEAN AVENUE CONDOMINIUM

PLAN
SCALE: 1"=20'

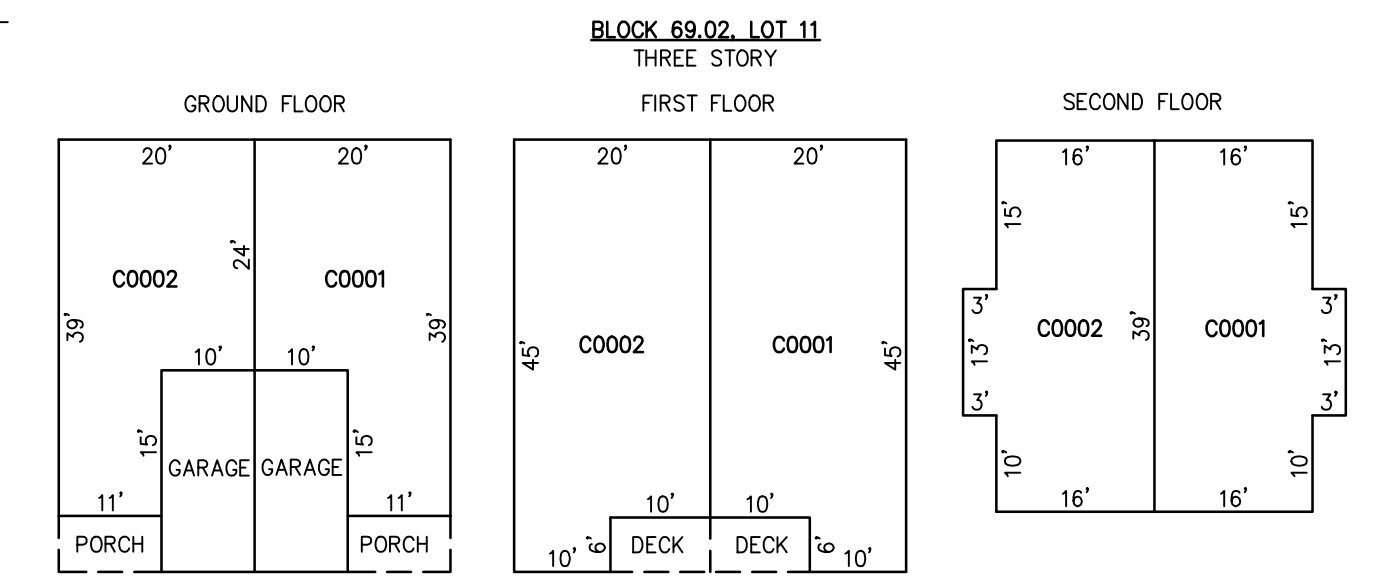
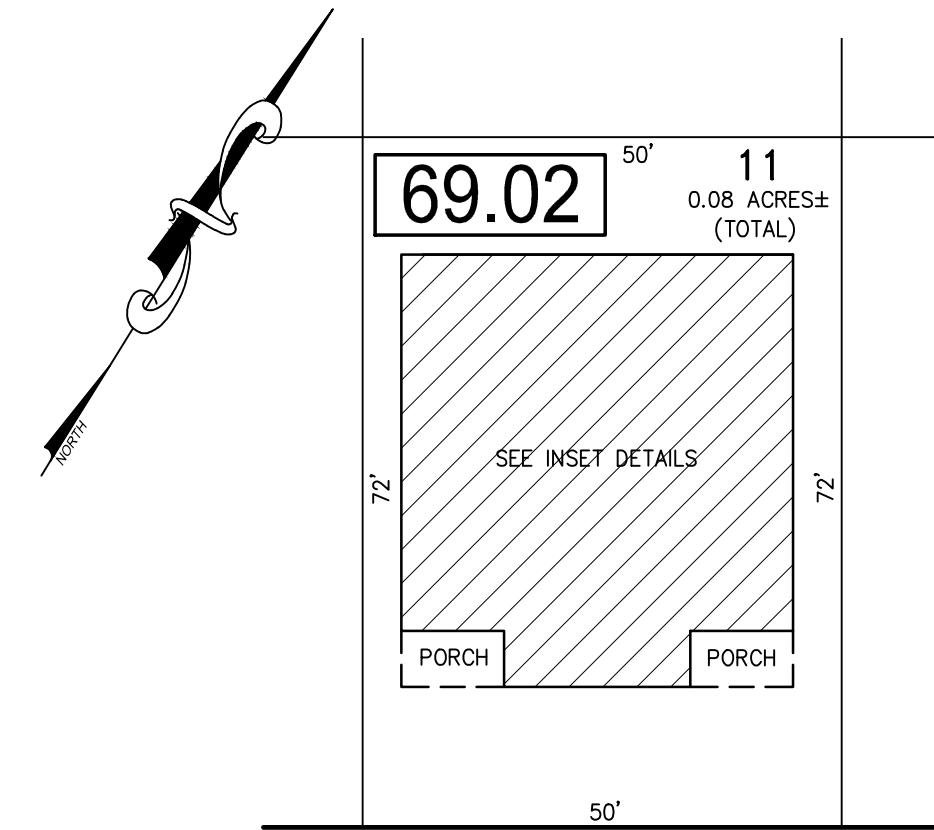

CONDO QUALIFIER	SQUARE FOOTAGE
C0001	1982 SF.
C0002	1982 SF.

DETAILS
SCALE: 1"=20'

BLOCK 69.02, LOT 11
OCEAN VILLA 6305-6307 OCEAN AVENUE CONDOMINIUM

PLAN
SCALE: 1"=20'

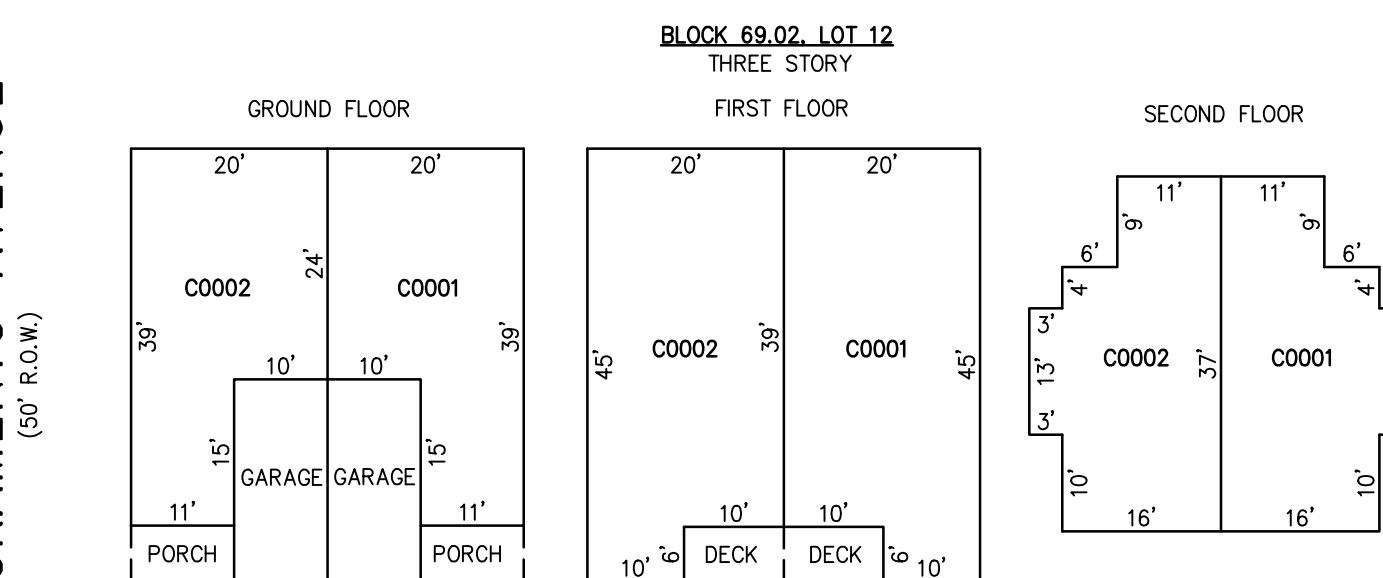
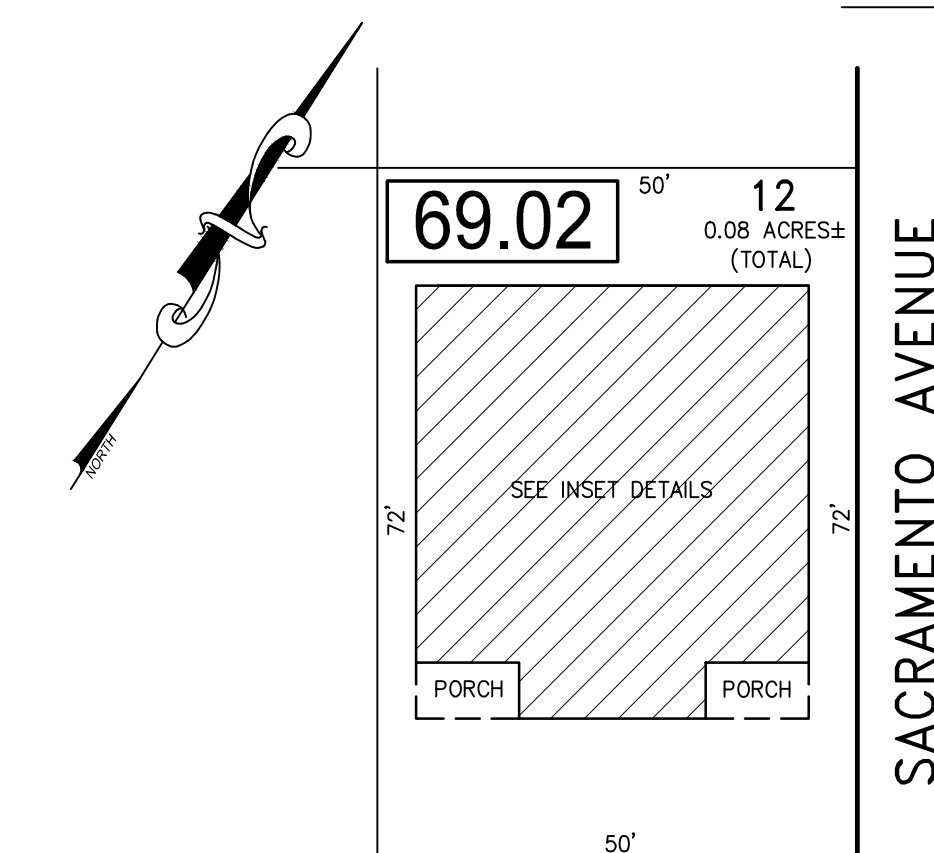

CONDO QUALIFIER	SQUARE FOOTAGE
C0001	2083 SF.
C0002	2083 SF.

DETAILS
SCALE: 1"=20'

BLOCK 69.02, LOT 12
OCEAN VILLA 6301-6303 OCEAN AVENUE CONDOMINIUM

PLAN
SCALE: 1"=20'

BLOCK 69.02, LOT 7
BLOCK 69.02, LOT 8
BLOCK 69.02, LOT 9
BLOCK 69.02, LOT 10
BLOCK 69.02, LOT 11
BLOCK 69.02, LOT 12
SEE SHEET 13

"THIS TAX MAP SHEET HAS BEEN DIGITALLY REVISED USING COMPUTER-AIDED DRAFTING/DESIGN (CADD) & COORDINATE GEOMETRY (COGO). IT IS BASED ON THE ORIGINAL DIGITALLY DRAWN TAX MAP PLATE BEARING THE OFFICIAL NEW JERSEY DIVISION TAXATION APPROVAL STAMP WITH APPROVAL DATE JULY, 20, 2016. SERIAL NUMBER 1070 AND SIGNATURE OF JUDY P. MILLER, C.T.A. CHIEF PROPERTY ADMINISTRATION AND SHELLY REILLY, C.T.A. PRINCIPAL FIELD REPRESENTATIVE. THE ORIGINAL DIGITALLY DRAWN TAX MAP PLATE WITH THE OFFICIAL APPROVAL STAMP IS ON FILE WITH REMINGTON & VERNICK ENGINEERS."

TAX MAP
CITY OF VENTNOR
ATLANTIC COUNTY NEW JERSEY
SCALE: NOTED DATE: 2-19-2015
CHARLES E. ADAMSON NJ PROFESSIONAL LAND SURVEYOR LIC. NO. 42627
REMININGTON, VERNICK & WALBERG ENGINEERS
845 N. MAIN STREET, PLEASANTVILLE, NJ 08232
(609) 645-700, FAX (609) 645-7076
WEB SITE ADDRESS: WWW.RVW.COM
TO SHOW CONDITIONS AS OF 3-01-2022