

REVISIONS		
DATE	NAME	NO.
2-10-2021	CHARLES E. ADAMSON	42627
3-1-2022	CHARLES E. ADAMSON	42627

NOTE:
THIS SHEET HAS BEEN DRAWN USING COMPUTER AIDED DRAFTING/DESIGN (CADD) AND COORDINATE GEOMETRY (COGO).

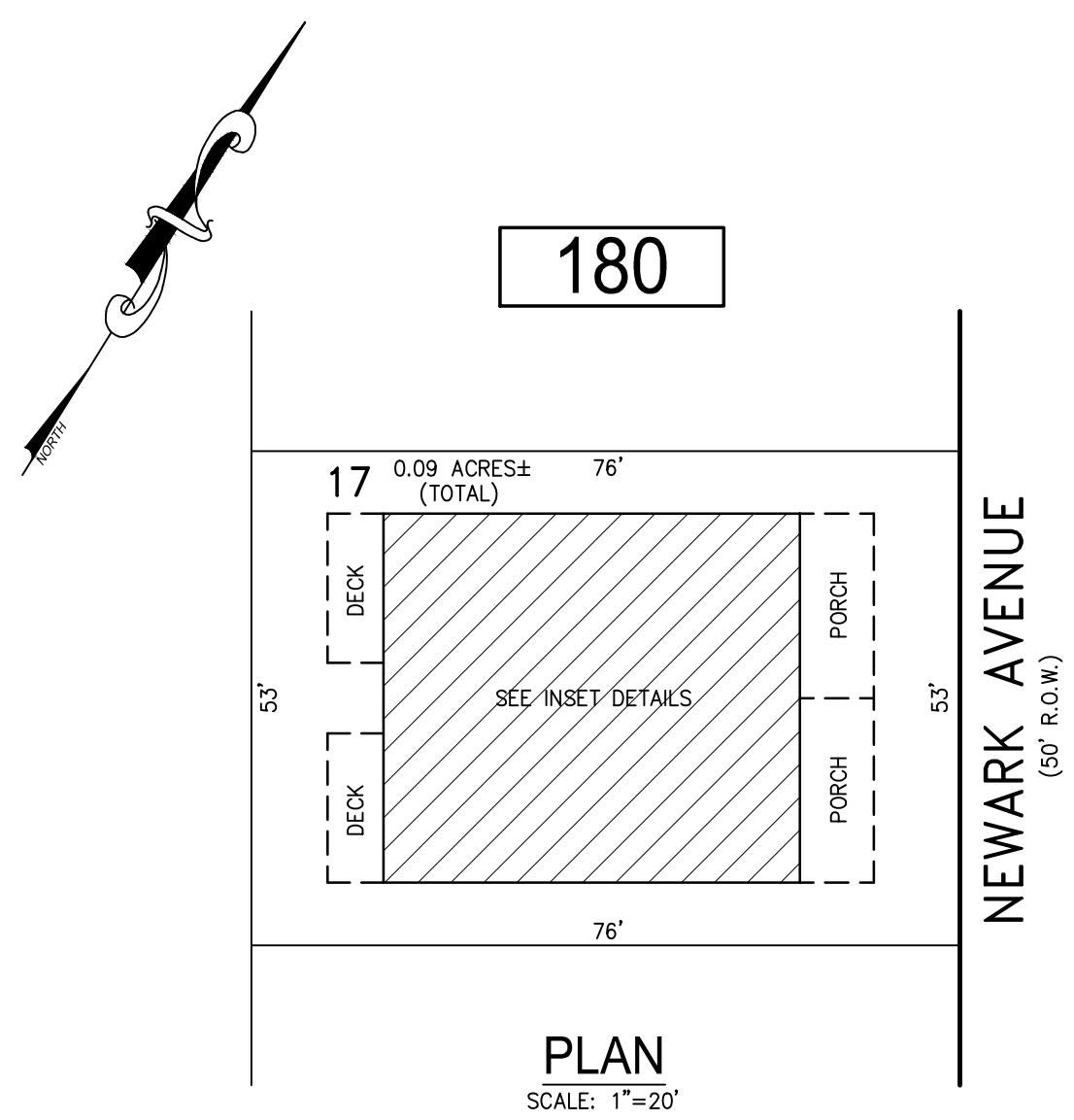

BLOCK 180, LOT 17
112 NORTH NEWARK AVENUE CONDOMINIUM

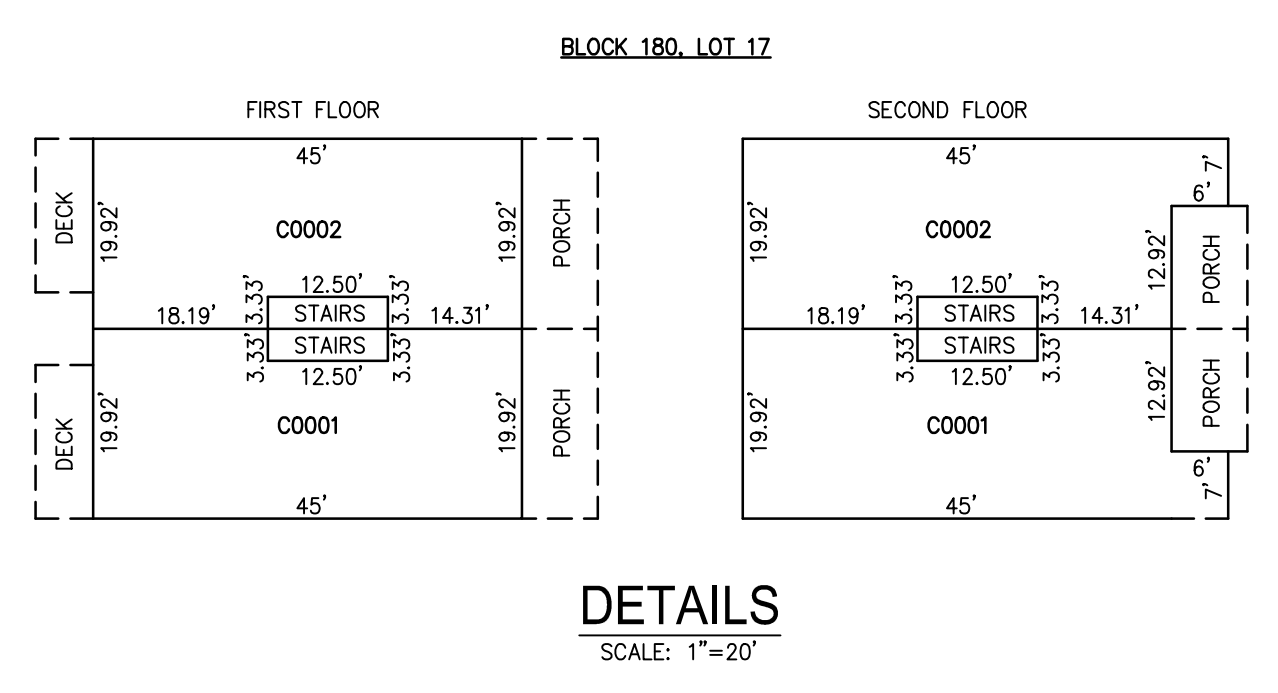

CONDO QUALIFIER	SQUARE FOOTAGE
C0001	2146 SF.
C0002	2146 SF.

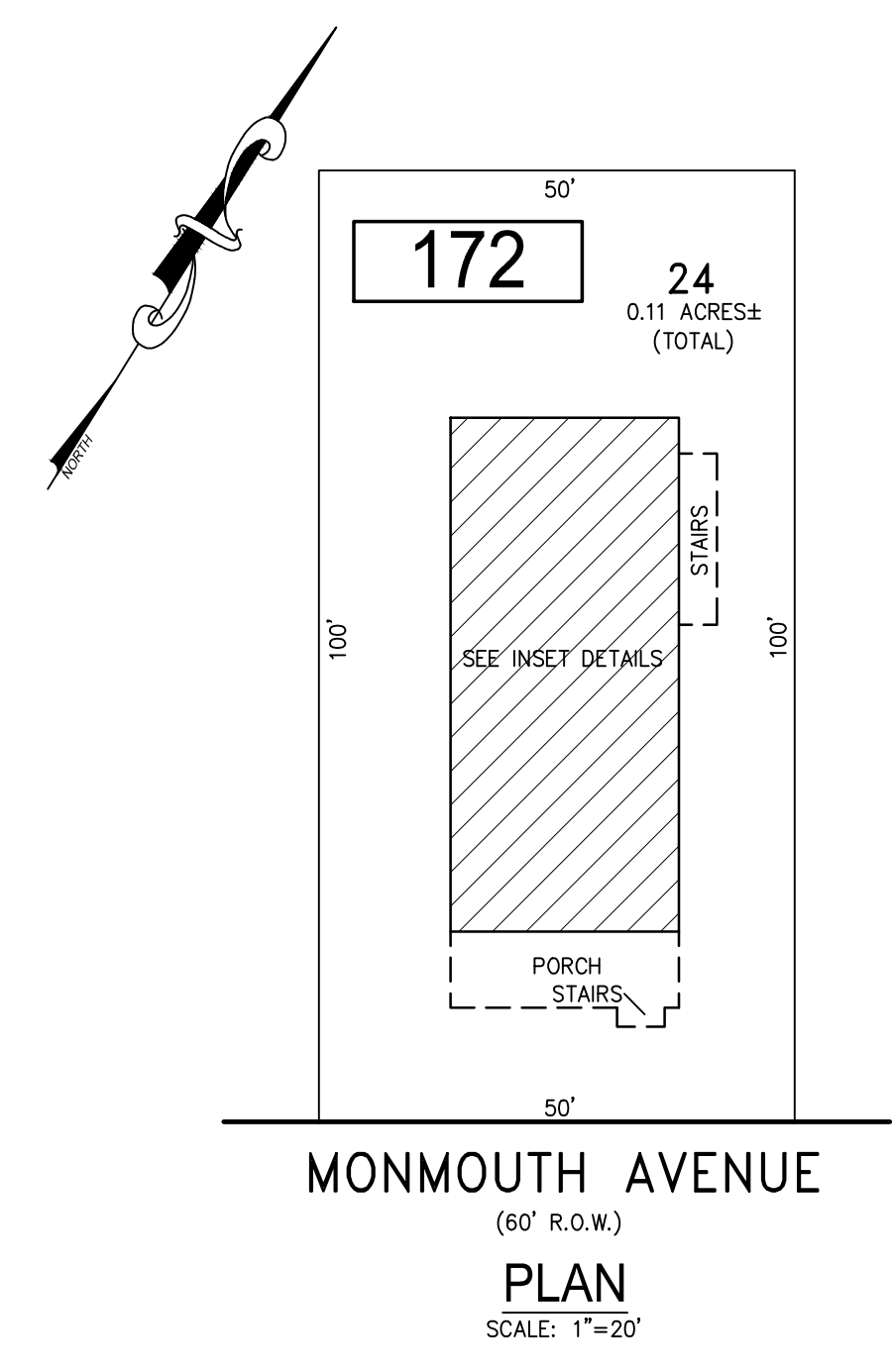

BLOCK 172, LOT 24
6915 WINCHESTER AVENUE CONDOMINIUM

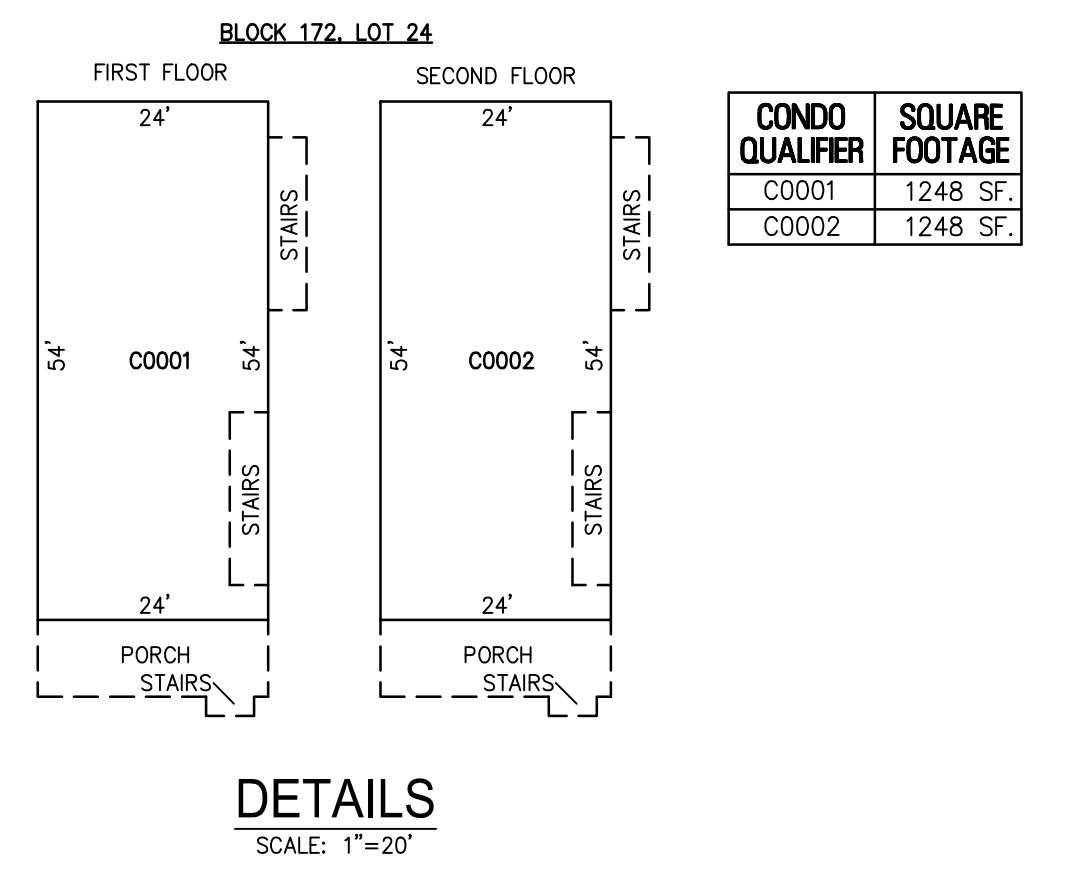

CONDO QUALIFIER	SQUARE FOOTAGE
C0001	1248 SF.
C0002	1248 SF.

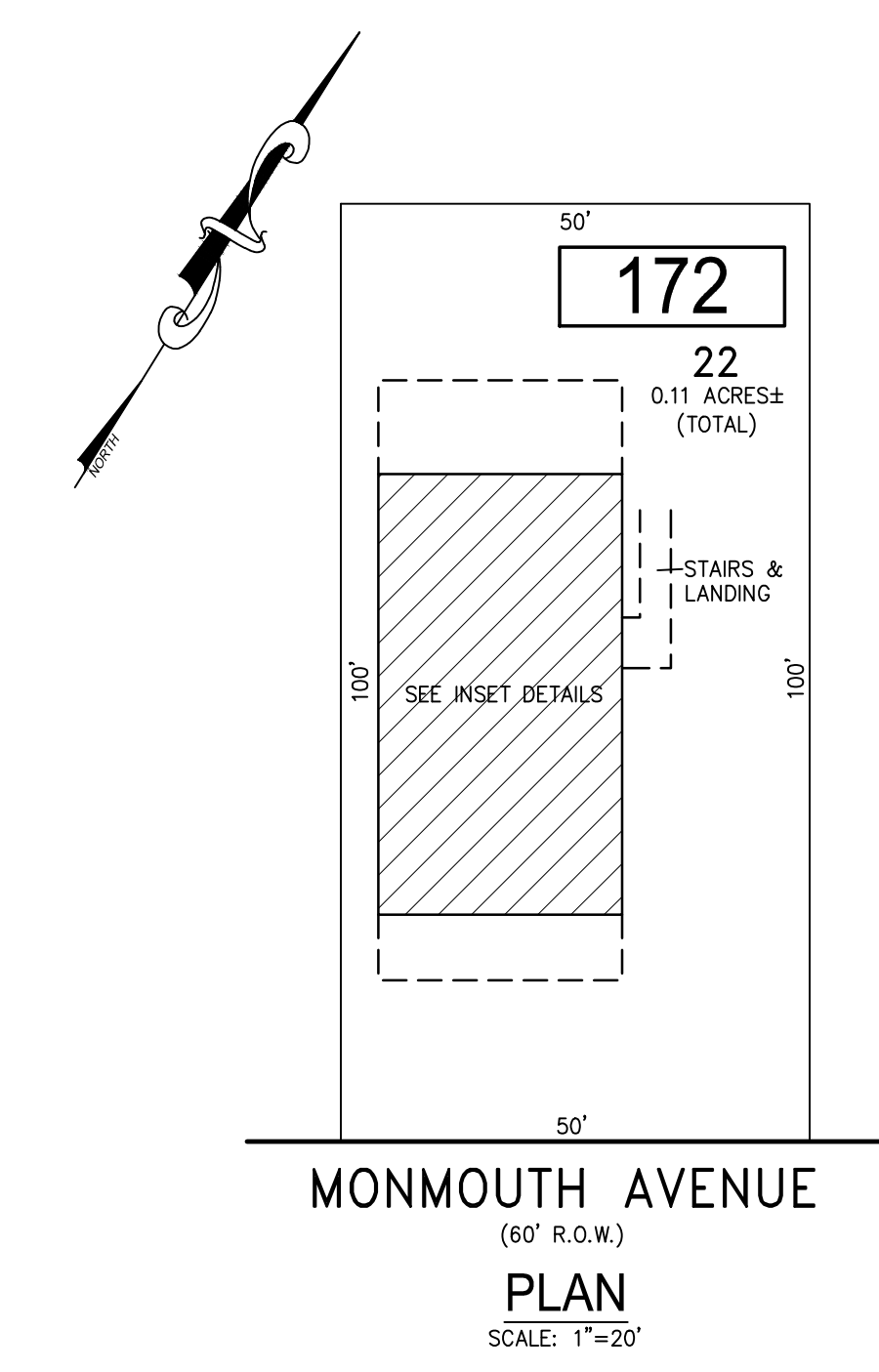

BLOCK 172, LOT 22
6807 MONMOUTH AVENUE CONDOMINIUM

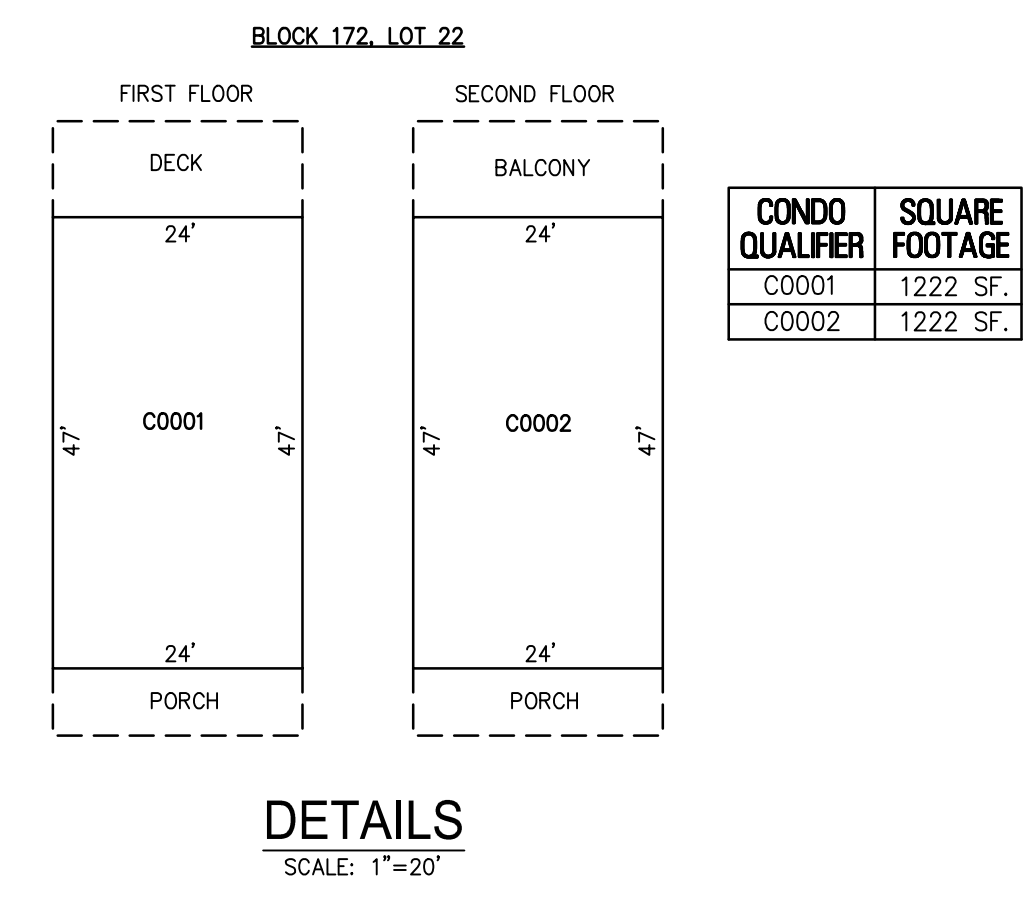

CONDO QUALIFIER	SQUARE FOOTAGE
C0001	1222 SF.
C0002	1222 SF.

BLOCK 180, LOT 17
BLOCK 172, LOT 22
BLOCK 172, LOT 24
SEE SHEET 30

"THIS TAX MAP SHEET HAS BEEN DIGITALLY REVISED USING COMPUTER-AIDED DRAFTING/DESIGN (CADD) & COORDINATE GEOMETRY (COGO). IT IS BASED ON THE ORIGINAL DIGITALLY DRAWN TAX MAP PLATE BEARING THE OFFICIAL NEW JERSEY DIVISION TAXATION APPROVAL STAMP WITH APPROVAL DATE JULY, 20, 2016. SERIAL NUMBER 1070 AND SIGNATURE OF JUDY P. MILLER, CTA, CHIEF PROPERTY ADMINISTRATION AND SHELLY REILLY, CTA, PRINCIPAL FIELD REPRESENTATIVE. THE ORIGINAL DIGITALLY DRAWN TAX MAP PLATE WITH THE OFFICIAL APPROVAL STAMP IS ON FILE WITH REMINGTON & VERNICK ENGINEERS."

TAX MAP
CITY OF VENTNOR
ATLANTIC COUNTY NEW JERSEY
SCALE: NOTED DATE: 2-19-2015
CHARLES E. ADAMSON NJ PROFESSIONAL LAND SURVEYOR LIC. NO. 42627
RV & W REMINGTON, VERNICK & WALBERG ENGINEERS
845 N. MAIN STREET, PLEASANTVILLE, N.J. 08232
(609) 645-7100, FAX (609) 645-7076
WEB SITE ADDRESS: WWW.RVE.COM
TO SHOW CONDITIONS AS OF 3-01-2022